

Instruction manual

2270 Ultrasonic Level Sensor



Content

1. Safety and responsibility	2
1.1 Intended use	2
1.2 Safety regulations for the Ex approved units.....	2
2. Transport and Storage	2
3. Design and Function	2
3.1 Design	2
3.2 Function	3
3.3 Basic concepts and elements of the ultrasonic measurement.....	4
3.4 Identifikation.....	4
4. Technical Data	5
4.1 Dimensions.....	6
4.2 Scope of delivery	6
5. Installation	7
5.1 Liquid Level Measurement	7
5.2 Wiring.....	9
6. Putting into operation	10
6.1 Usage	10
7. Programming	11
7.1 Measurement configuration	11
7.2 Current output.....	16
7.3 Digital communication.....	17
7.4 Measurement optimisation.....	17
7.5 Volume (content) measurement.....	20
7.6 Open channel flow measurement	21
7.7 32-Point-Linearisation.....	24
7.8 Information parameters (read out parameters).....	25
7.9 Additional parameters of the flow metering.....	26
7.10 Other parameters.....	26
8. Maintenance	26
9. Error codes	27
10. Parameter table	28
11. Sound velocity values in different gases	30
12. Article overview	30
13. Disposal	31

1. Safety and responsibility

1.1 Intended use

The 2270 Ultrasonic Level Sensors are excellent tools for level measurement of liquids. Level measurement technology based on the non-contacting ultrasonic principle is especially suited for applications where, for any reason, no physical contact can be established to the surface of the material to be measured.

1.2 Safety regulations for the Ex approved units

Diameter of the cable should match the cable conduit. The cable outside the unit should be fixed so that it should be free of loading. The terminal box should be selected in accordance with the electrical class of the area. Transmitter can only be powered by certified intrinsically safe current loop.

The enclosure of the transducer is plastic that can be loaded electrostatically therefore:

- ▶ Filling and emptying speed should be selected according to the medium
- ▶ Fog development of the dangerous material during filling should be avoided.
- ▶ Cleaning of the plastic enclosure is not allowed in hazardous space.
- ▶ The apparatus is not suitable for flame-barrier between the space and the outside area.

2. Transport and Storage

- ▶ Transport and/or store product in unopened original packaging.
- ▶ Protect product from dust, dirt, dampness as well as thermal and UV radiation.
- ▶ Make sure that the product has not been damaged neither by mechanical nor thermal influences.
- ▶ Check product for transport damages prior to the installation.

3. Design and Function

3.1 Design



3.2 Function

The ultrasonic level metering technology is based on the principle of measuring the time required for the ultrasound pulses to make a round trip from the sensor to the level to be measured and back. The sensor emits an ultrasonic pulse train and receives the echoes reflected. The intelligent electronic device processes the received signal by selecting the echo reflected by the surface and calculates from the time of flight the distance between the sensor and the surface which constitutes the basis of all output signals of the 2270 Ultrasonic Level Sensor.

A Total beam angle of 5° - 7° at -3 dB as is featured by transducers of transmitters and sensors ensuring a reliable measurement in narrow silos with uneven side walls as well as in process tanks with various protruding objects.

Furthermore, as a result of the narrow beam angle - the emitted ultrasonic signals have an outstanding focusing - deep penetration through gases, vapour and foam is ensured.

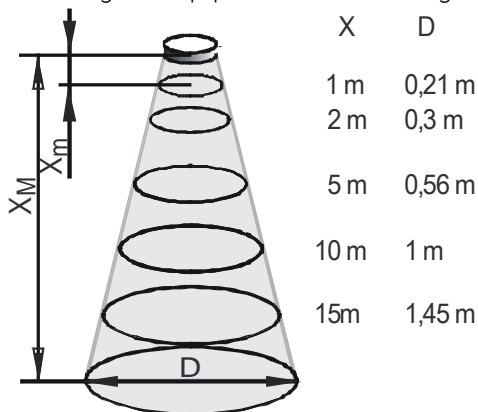

Diameters corresponding to 5° beam angle.

Minimum measuring distance (X_m) is determined by the design of the unit within which the measurement is not possible (Dead Zone) its value is according with P05. Since measurement is impossible within this range material should not get into this zone

Maximum measuring distance (X_M) is the greatest distance (determined by the design of the unit) which can be measured by the unit under ideal conditions. (See parameter P04). Maximum measuring distance of the actual application (H) must not be greater than X_M .

3.3 Basic concepts and elements of the ultrasonic measurement

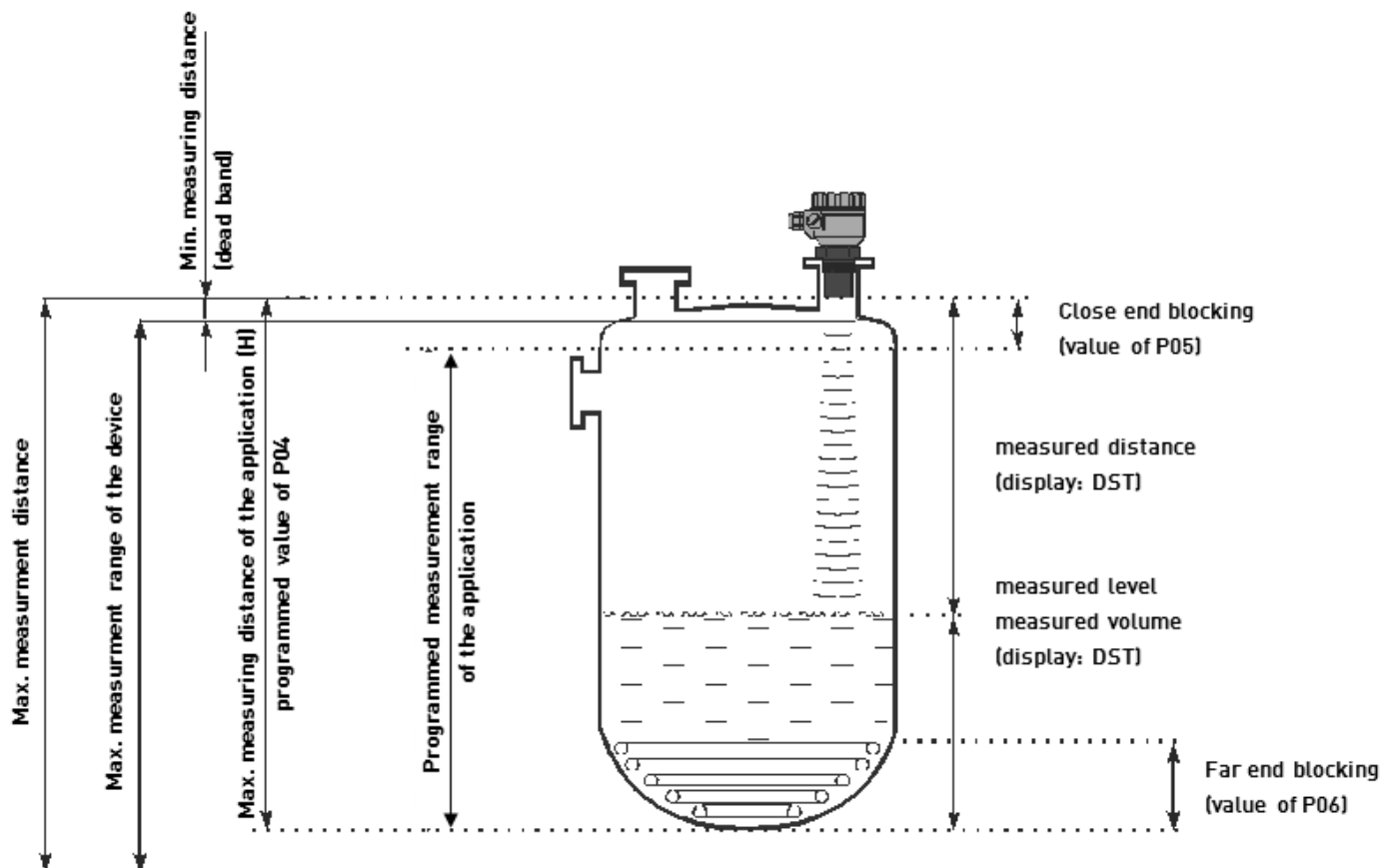

3.4 Identifikation

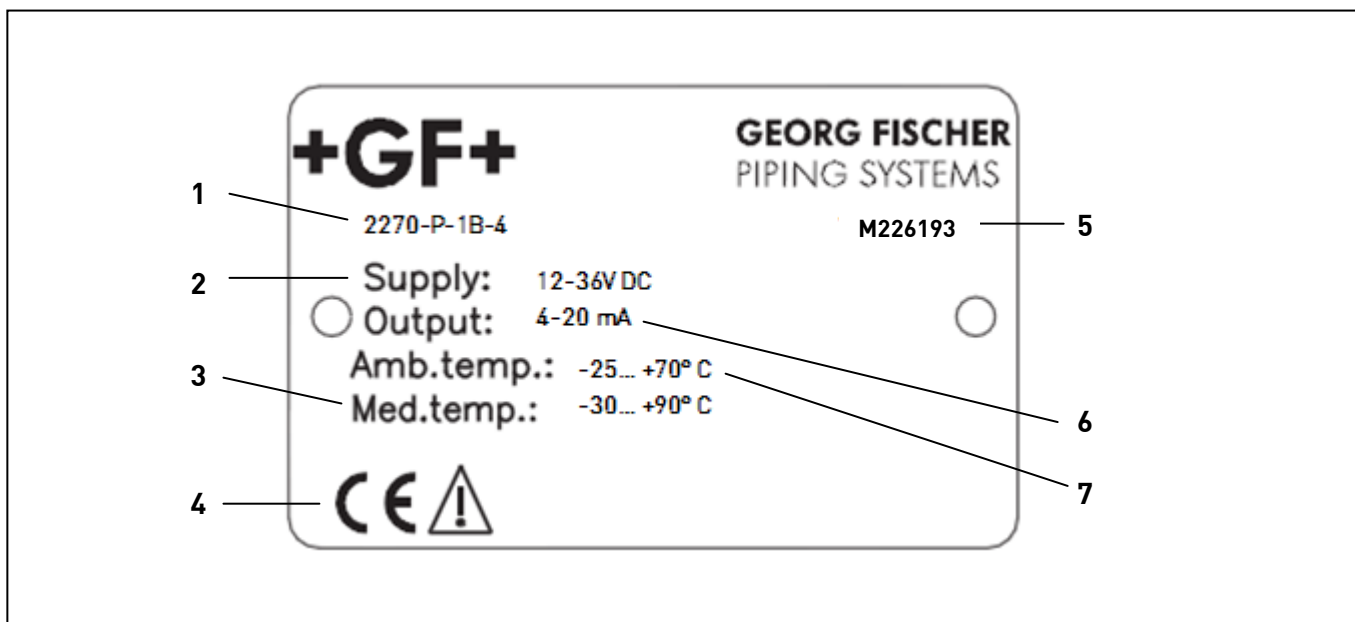

1	Type	5	Serial code
2	Media temperature	6	Output
3	Voltage	7	Ambient temperature
4	CE-marking		

4. Technical Data

General		
Type	2270-X-XX-4	2270-X-XX-6
Range	0.2 to 4 m / 0.65 to 13 ft	0.25 to 6 m / 0.82 to 20 ft
Total Beam Angle	6°	5°
Accuracy *	± (0.2 % of measured distance, 0.05 % of range)	
Environmental		
Process temperature	-30 °C to 80 °C	
Process pressure (absolute)	0.03 to 0.3 MPa (0.3 to 3 bar)	
Process connection	1 in. or 1½ in. BSP / NPT	1 in. or 2 in. BSP / NPT
Enclosure		
Resolution (dep. on distance)	<2 m: 1 mm, 2 to 5 m: 2 mm, 6 m: 5 mm	
Ingress Protection	IP 68 / NEMA 6P	
Outputs	2-wire 4 to 20 mA, HART protocol, max. 600 Ω	2-wire 4 to 20 mA, HART protocol, max. 600 Ω
Electrical		
Power Supply	11.8 to 36 V DC	
Power Consumption	48 mW to 720 mW	
Housing material	PP or PVDF	
Cable material	Cable sealing: EPDM, cable isolation: PVC	
Connection	6 x 0,5 mm ² shielded cable, Ø 6 mm; standard length 5 m (max. 30 m)	

* Under optimal circumstances of reflection and stabilised transducer temperature.

Additional data for EX certified devices

Ex marking	II1G EEx ia IIB T6 IP68
Intrinsically safety data	$C_i \leq 15 \text{ nF}$, $L_i \leq 200 \mu\text{H}$, $U_i \leq 30 \text{ V}$, $I_i \leq 140 \text{ mA}$, $P_i \leq 1 \text{ W}$ Ex-device should be powered by EEx ia power supply.
Ex power supply, loading	$U_0 < 30 \text{ V}$, $I_0 < 140 \text{ mA}$, $P_0 < 1 \text{ W}$, Voltage range 12...30 V, $R_{t \text{ max}} = (U_s - 12 \text{ V}) / 0,02 \text{ A}$
Medium temperature	PP transducer -20 °C ... +70 °C, PVDF transducer -20 °C ... +80 °C,
Ambient temperature	-20 °C ... +70 °C

4.1 Dimensions

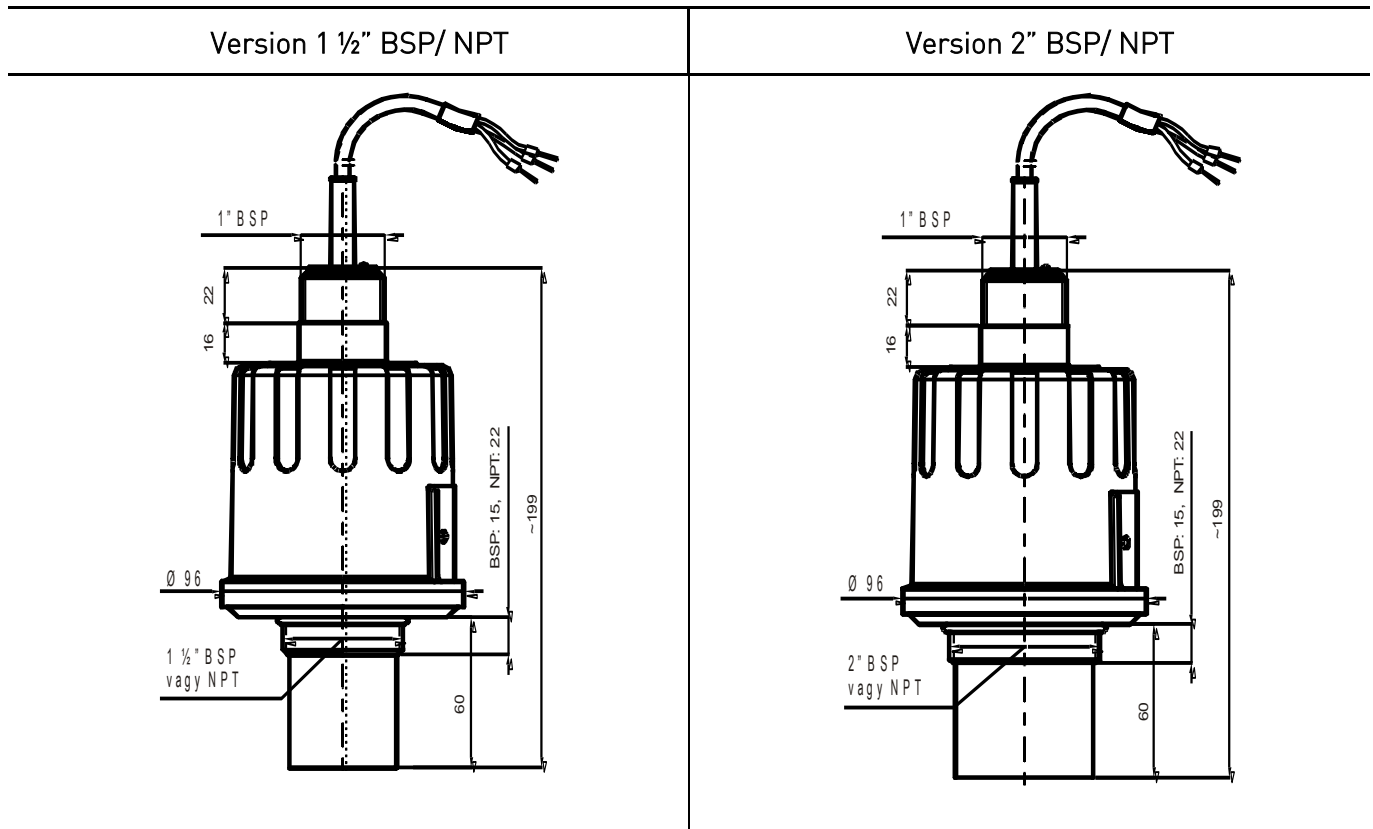

4.2 Scope of delivery

- Installation and Programming Manual

5. Installation

5.1 Liquid Level Measurement

Position

The optimal position of the Compact Ultrasonic Level Transmitter Type 2260 is on the radius
 $r = (0.3 \dots 0.5) R$ of the (cylindrical) tank / silo.
 (Take also sonic cone on page 1 into consideration.)

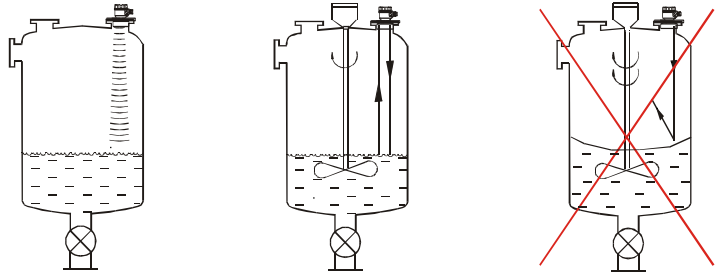

Sensor alignment

The sensor face has to be parallel to the surface of the liquid within $\pm 2-3^\circ$.

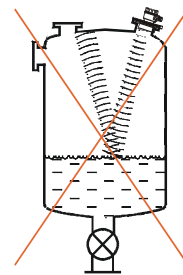

Temperature

Make sure that the Ultrasonic Level Transmitter Type 2260 will be protected against overheating by direct sunshine.

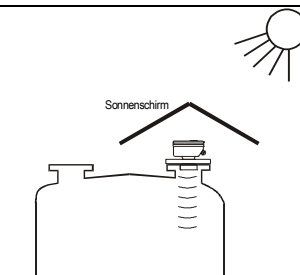

Obstacles

Make sure that no in-flow path or objects (e.g. cooling pipes, ladders, bracing members, thermometers, etc.) or no tank wall of the ragged surface protrude into the sensing cone of the ultrasonic beam.

One fix object in the tank / silo that disturb the measurement can be blocked out by the appropriate programming of the Ultrasonic Level Transmitters Type 2260 – see parameter P29 “Blocking out of disturbing object”

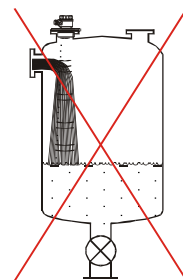

Foam

Foaming of the liquid surface may render ultrasonic level metering impossible. If possible, a location should be found, where foaming is the least (device should be located as far as possible from liquid inflow) or a stilling pipe or well should be used.

Stand-off

The structure of the stand off pipe should be rigid; the inner rim where the ultrasonic beam leaves the pipe should be rounded.

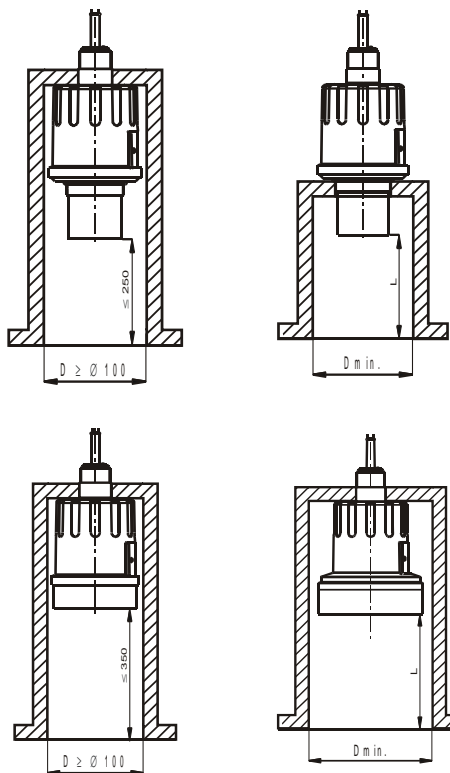

L	Dmin	
	BSP/ NPT 1 1/2"	BSP/ NPT 2"
150	50	60
200	50	60
250	65	65
300	80	75

Wind

Intensive air (gas) movements in the vicinity of the ultrasonic cone is to be avoided. A strong draft of wind may "blow away" the ultrasound. Devices with lower measuring frequency (40, 20 kHz) are recommended.

Fumes/ Vapours

For closed tanks containing chemicals or other liquids, which creates fume/gases above the liquid surface especially for outdoor tanks exposed to the sun, a strong reduction of the nominal measuring range of the ultrasonic device is to be considered during device selection.

Devices with lower measuring frequency (40, 20 kHz) are recommended in these cases units.

5.2 Wiring

- ▶ Make sure the terminals in the box are not under power (Use shielded cable $6 \times 0.5 \text{ mm}^2$ suggested in the technical data or stronger).
- ▶ After powering the necessary programming can be performed.

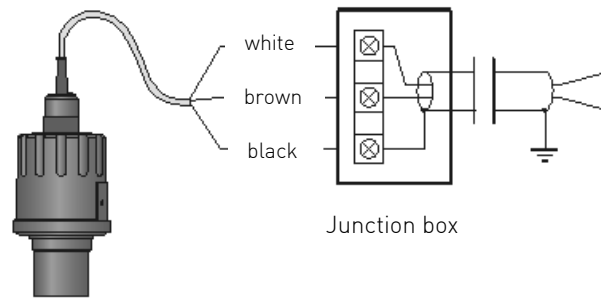

Wire colours:

White - **I+** one of the points of current loop, power supply and HART (polarity independent)

Brown - **I-** other point of current loop, power supply and HART (polarity independent)

Black - **GND** functional earthing and shielding point

Extension of the integrated cable:

Should extension be needed the use of connection box is suggested.

The shielding of the two cables should be connected and grounded at the signal processing device.

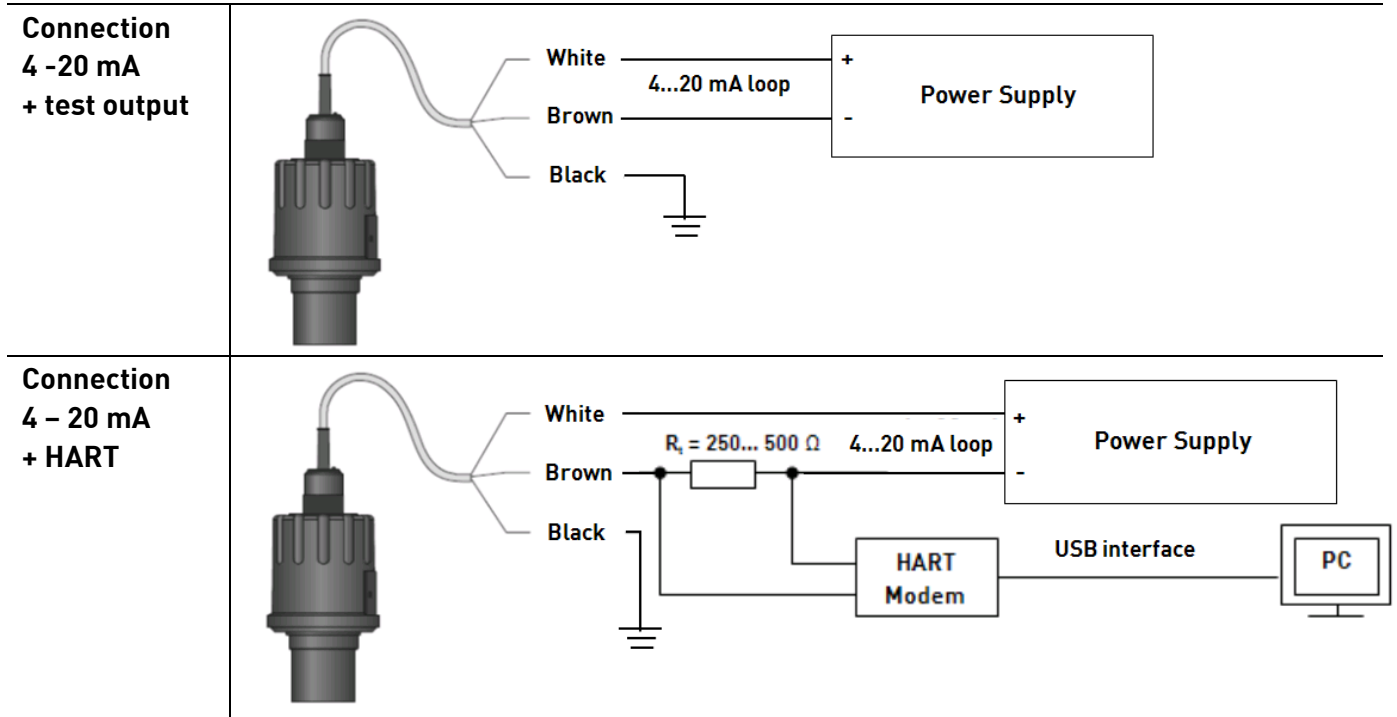

**Connection
9900
Universal
Transmitter**

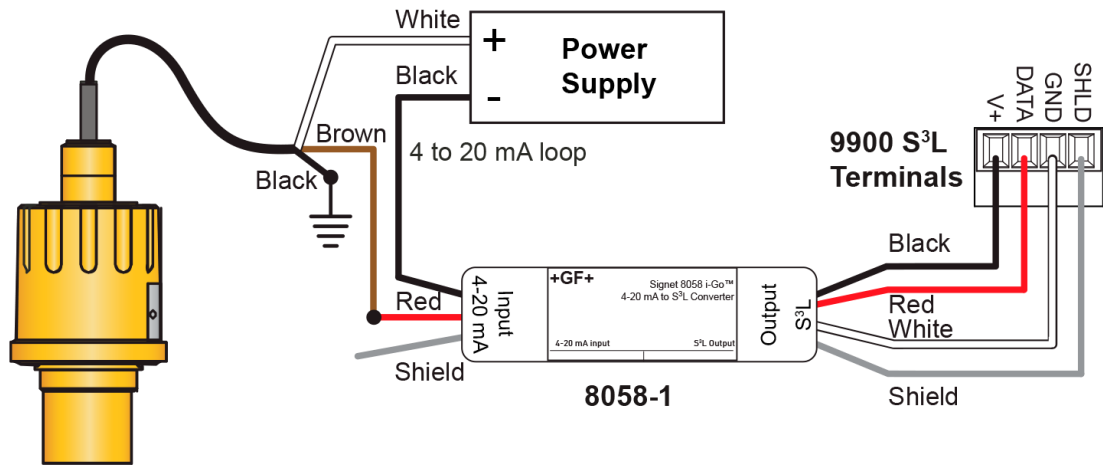

6. Putting into operation

6.1 Usage

Subsequent to powering the correctly wired device would start to tick and after 10 - 20 s ECHO LED go on and 4 ... 20 mA signal appears on the current output. Measurement will be according to the factory setting. The factory setting is throughout apt to check proper working and to perform simple measurement tasks but features residing in the unit can only be utilised by adjusting the 2270 Ultrasonic Level Sensor to the application by programming. For sound knowledge of the operation features and proper solving of difficult measurement applications the parts of the programming should carefully be studied..

LED indication:

- **ECHO**-LED
ON, if the unit detects proper echo.
- **COM**-LED
See description „HART“

View from above:

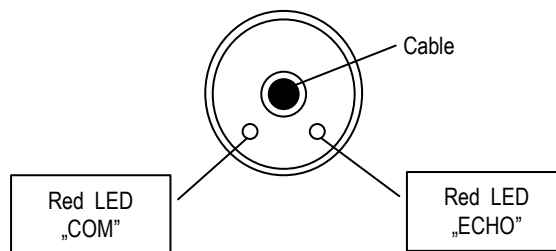

Device can be reset to factory setting. Default is the following:

- Measurement: level (LEV)
- Zero level assigned to the maximum distance
- Current output proportional to the level
- 4 mA and 0% assigned to zero level.
- 20 mA and 100% a assigned to the maximum level (minimum distance)
- Error indication by the current output: holds last value.
- Damping: 60 s.

7. Programming

The HART interface provides for access to the whole parameter set and possibility of their programming. Parameter set can be reached in the following way: by the use of the

- Eview light software run on the PC connected through HART modem to the loop or
- EViewLight Software-Download: www.gfps.com/eviewlight

7.1 Measurement configuration

P00: - c b a Engineering units

Programming of this parameter will result in loading the factory default with the corresponding engineering units. Therefore all parameters should be set again!

a	Operation	
0	Liquid level measurement	
b	Engineering units (according to "c")	
	Metric	US
0	m	ft
1	cm	Inch
c	Calculation system	
0	metric	
1	US	

Factory default: 000

P01: - - 1 a Measurement mode

Parameter value „a” will determine the basic measurement value that will be transmitted. Subsequently values for the relays are also relating to these quantities.

a	Measurement mode	Transmitted value	Display symbol
0	Distance	Distance	DIST
1	Level	Level	LEV
2	Level %		LEV%
3	Volume	Volume	VOL
4	Volume %		VOL%
5	Flow	Flow	FLOW

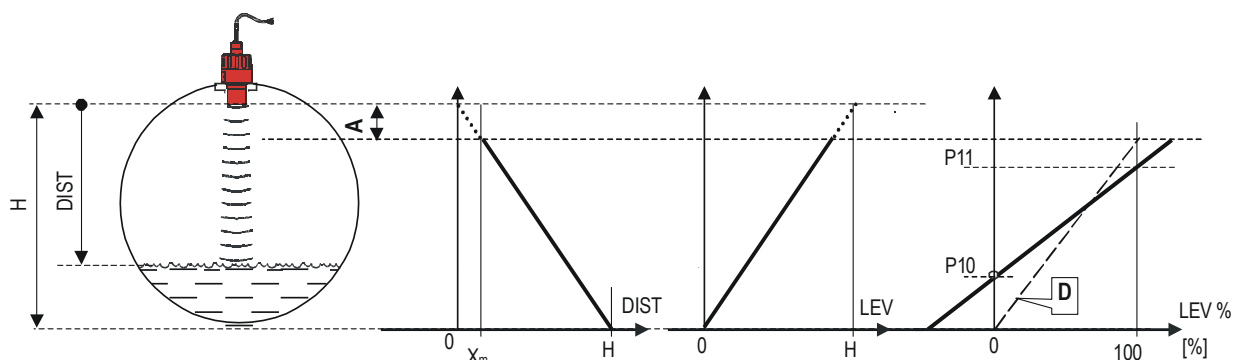

Transmitted value	DIST	LEV=H-DIST	$LEV\% = LEV \cdot \frac{P11 - P10}{H - X_m} + P10$
Parameters to set	P00 P01(a) = 0 P05 ↗ X_m	P00 P01(a) = 1 P04 = H P05 ↗ X_m	P00 P01(a) = 2 P04 = H P05 ↗ X_m P10 = $X_{0\%}$ P11 = $X_{100\%}$

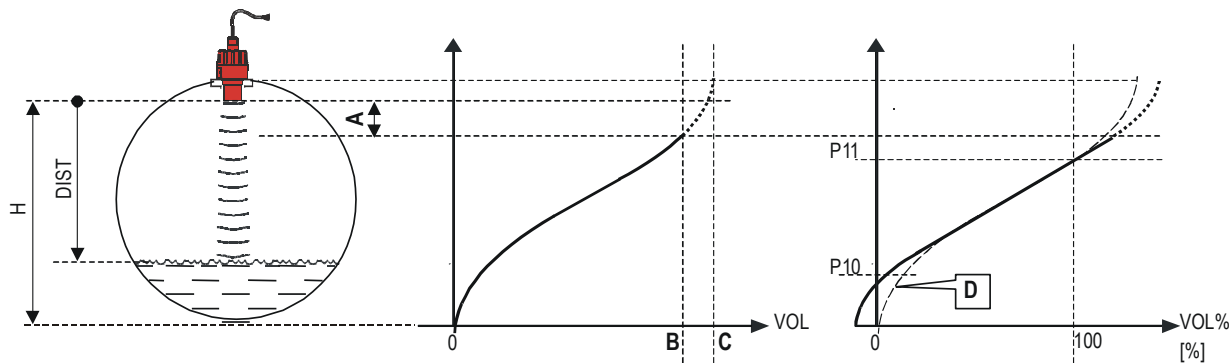

Transmitted value	VOL $f_{P40...P45}(H-DIST)$	$VOL\% = VOL \cdot \frac{P11 - P10}{H - X_m} + P10$
Parameters to set	P00 P01(a) = 3 P02(b) P04 = H P05 ↗ X_m P40...P45	P00 P01(a) = 4 P02(b) P04 = H P05 ↗ X_m P10 = $X_{0\%}$ P11 = $X_{100\%}$ P40...P45

Description of the figures:

- A:** Shortest measurable distance
- B:** Volume (content) pertaining to the greatest measurable level
- C:** Whole value of the vessel
- D:** diagram valid for the default value of P10 P11

Factory default: 11

P02: - c b a Calculation units

a	Temperature
0	°C
1	°F

This table is interpreted according to P00(c), P01(a) and P02(c) and is irrelevant in case of percentage measurement [P01(a)= 2 or 4]

b	Volume		Weight (see also P32)		Volume flow	
	Metric	US	Metric	US	Metric	US
0	m ³	ft ³	-	lb (pound)	m ³ /time	ft ³ /time
1	litre	gallon	tons	tonnes	litre/time	gallon/time

c	Time
0	s
1	min
2	hour
3	day

Attention!

2270 Ultrasonic Level Sensor is a level transmitter. Although it can be used for measuring weight, due to factors involved in doing so, accuracy may essentially be influenced.

Factory default: 000

P04 - - - - Maximum distance to be measured (H)

This is the only parameter that has to be programmed for each application other than distance (however to avoid disturbing effect of possible multiple echoes it is suggested to do this in distance measurement applications too).

The maximum distance to be measured is the greatest distance between the surface of the transducer and the farthest level to be measured. The factory programmed, greatest distances (DEFAULT values) which can be measured by the units are listed in the table below. For the actual application the maximum distance to be measured i.e. the distance between the sensor and the bottom of the tank should be entered in P04.

2270 Ultrasonic Level Sensor for liquids	Maximum measuring distance X _M [m/ft]
	Transducer material PP/ PVDF
Version I	4/13
Version II	6/20

Since the level is determined by calculating the difference between the value set in P04 and distance (DIST) is measured by the unit, it is essential that the correct value of (H) is set in P04. To obtain the best accuracy it is suggested that this distance is measured in the empty tank.

Factory default: X_M as per chart

P05: - - - - Minimum measuring distance (Dead-zone – Close-end blocking)

The range, beginning with the sensor's surface, within which (due to the physical restraint of the ultrasound measurement system) measurement can not be made, is called the dead zone. The 2270 Ultrasonic Level Sensor will not accept any echo within the blocking distance set here.

Close-end blocking may be represented as the extension of the dead zone within which a possible echo will not be taken into consideration making possible to exclude disturbing objects near to the sensor.

Automatic Close-end blocking =Dead Band control (P05 = X_m)

Device with factory default will automatically *set the smallest possible dead band* depending on the conditions of the operation.

This will be under optimal conditions a bit smaller in unfavourable circumstances greater than value given in the chart.

Manual Close-end-blocking with limitation \nearrow dead zone (P05 > X_m)

By entering a value, higher than the factory default the close-end blocking will be either the value programmed in P05 or the actual dead zone distance (influenced by the actual conditions of the application) whichever is greater.

2270 Ultrasonic Level Sensor for liquids	Minimum measuring distance X_m [m/feet]
	Sensor material PP/ PVDF
Version I	0.2/0.65
Version II	0.25/0.82

Factory default : X_m as per chart

P06: - - - - Far-end blocking

Far-end blocking is the range below the level set in parameter P06. The far-end blocking can be used to avoid disturbing effect of stirrer or heaters at the bottom of the tanks. Detecting echoes in this range the unit provides special signals.

A.) Measuring level or content

- Level sinking below:
 - the value of P06 current output is according to the value of the far-end blocking and further
 - below SUB 0 (7/8 of P06) the ERROR CODE 10 will be transmitted via HART
- Level rising over value of far-end blocking: The calculation of level and volume will be based on the programmed tank dimensions, therefore the measured or calculated process values will not be influenced in any way, by the far end blocking value.

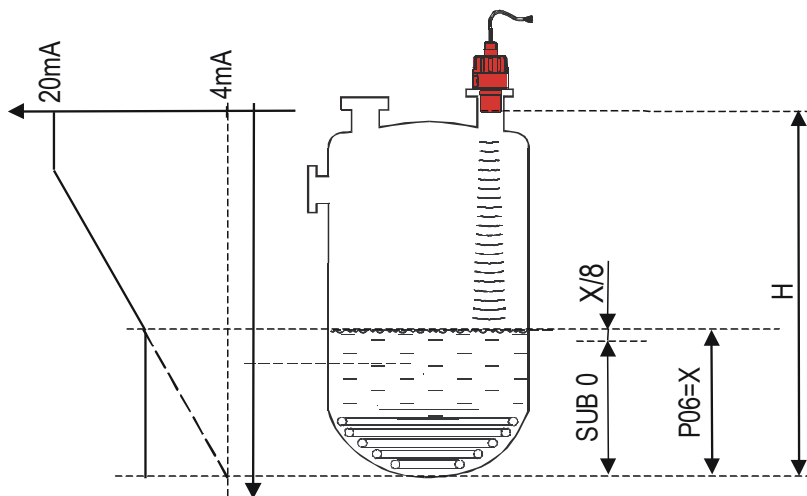

B.) Open channel flow metering

Far-end blocking will be used for those small levels below which the accurate volume flow calculation is no longer possible.

- Level in the flume/weir sinking below the blocked out range:
 - Output current value will be according to the value of $Q = 0$
 - 0 value transmitted via HART for display of „No Flow” or 0
- Level in the flume/weir rising over the blocked out range:

The calculation of volume flow will be based on the programmed flume/weir data; therefore the measurement values will not be influenced in any way, by the far end blocking value.

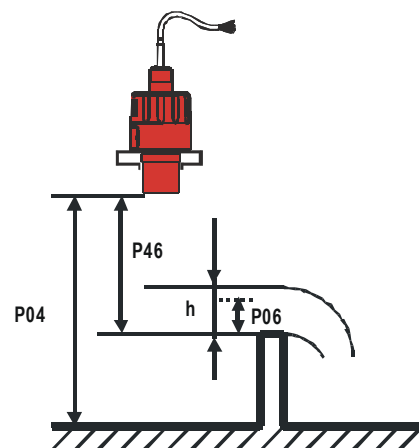

Factory default: 0

7.2 Current output

P08: - - - - Fixed current output

By this step the output current can be set for a fix value selected from between 3.8 mA and 20.5 mA. This function is not operational as per the factory default: 0.

Attention: fixing output current will make settings in P10, P11, P12 and P19 irrelevant.

Factory default: 0

P10: - - - - Value (of distance, level, volume or flow) assigned to 4 mA current output

Factory default: 0

P11: - - - - Value (of distance, level, volume or flow) assigned to 20 mA current output

Values are interpreted according to P01(a). Assignment can be made so that the proportion between the change of the (measured or calculated) process value and the change of the current output be either direct or inverse. E.g. level 1 m assigned to 4mA and level 10 m assigned to 20 mA represents direct proportion and level 1 m assigned to 20 mA and level 10 m assigned to 4 mA represents the inverse proportion. Please note that in case of programming for (LEV or VOL) % measurement the min and max value has to be entered in the relevant engineering units of LEV (m, ft) or VOL (m³, ft³).

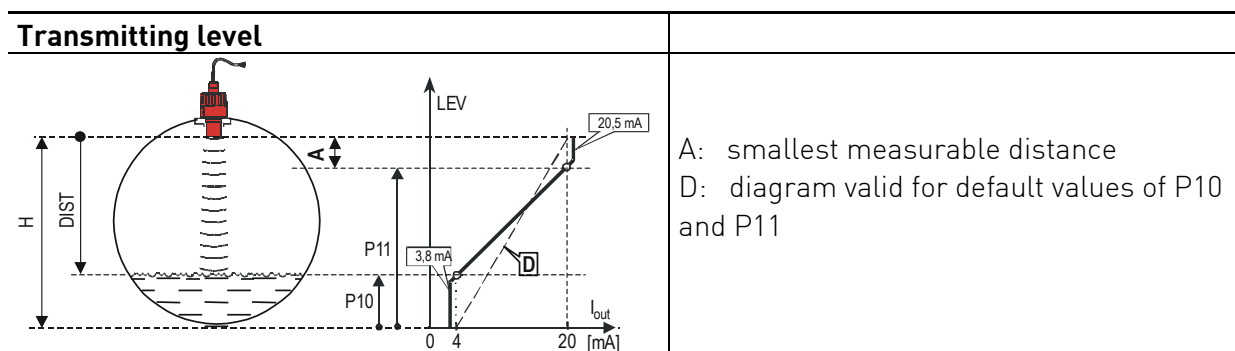

Factory default: $X_M - X_m$ (see table P04 and P05)

P12: - - - a Error indication by the current output

In case of error the 2270 Ultrasonic Level Sensor will provide one of the current outputs below for the time the error prevails.

a	Error indication by output current
0	HOLD (letzter Wert halten)
1	3,8 mA
2	22 mA

Factory default: 0

7.3 Digital communication

P19: - - - a Short (HART) address of the unit

These addresses with 0 ... 15 are, in accordance with the HART standard, for distinguishing units in the same loop.

- Address: 0 current output of 4 ... 20 ma operational
- Address: 1 ... 15 current output is fixed to 4 mA.

Factory default: 2

7.4 Measurement optimisation

P20: - - - a Damping

This parameter can be used to reduce unwanted fluctuation of the display and output.

a	Damping (s)	LIQUIDS	
		No or moderate fume/ waves	heavy or dense fume or turbulent waves
0	no filter	for testing only	
1	3	applicable	not recommended
2	6	recommended	applicable
3	10	recommended	recommended
4	30	recommended	recommended
5	60	recommended	recommended

Factory default: 5

P22: - - - a Dome top tank compensation

This parameter can be used to reduce disturbing effect of possible multiple echoes.

a	Compensation	Remark
0	OFF	In case the 2270 Ultrasonic Level Sensor is not mounted in the centre of the top and the top is flat.
1	ON	In case the 2270 Ultrasonic Level Sensor is mounted in the centre of a tank with dome-shaped top

Factory default: 0

P24: - - - a Target tracking speed

In this parameter evaluation can be speed up at the expense of the accuracy.

a	Tracking speed	Remark
0	Standard	For most applications
1	Fast	For fast changing level
2	Special	Only for special applications (measuring range is reduced to 50% of the nominal value) The measuring window is inactive and the 2270 Ultrasonic Level Sensor will respond practically instantly to any target

Factory default: 0

P25: - - - a Selection of Echo within the measuring window

A so-called measuring window is formed around the echo signal. The position of this measuring window determines the flight time for calculation of the distance to the target. (the picture below can be seen on the test oscilloscope).

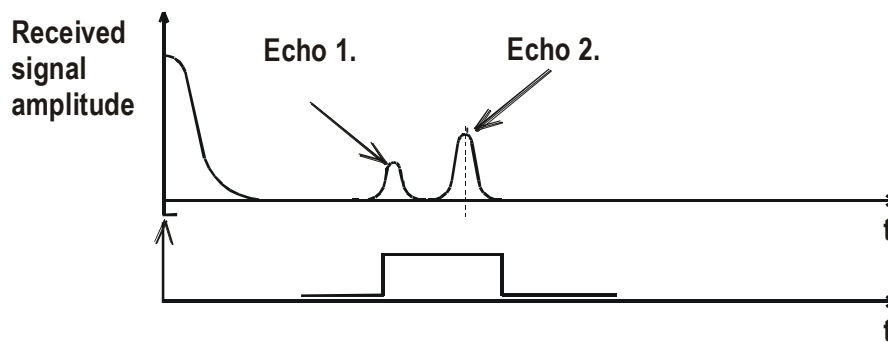

Some applications involve multiple (target + disturbing) echoes even within the measuring window. Basic echo selection will be done by the Quest + software automatically. This parameter influences the echo selection only within the measuring window..

a	Echo in the window to be selected	Remark
0	With the highest amplitude	Most frequently used
1	First one	For liquids applications with multiple echoes within the Measuring Window

Factory default: 0

P26: Level elevation rate (filling speed) (m/h or ft/h)

Factory default: 2000

P27: Level descent rate (emptying speed)) (m/h or ft/h)

These parameters provide additional protection against echo loss in applications involving very heavy fuming. Correct setting increases reliability of the measurement during filling and emptying. The parameters must not be smaller than the fastest possible filling/emptying rate of the actual technology.

Attention! Level changing rate is rather different near to the conical or spherical bottom of such a vessel.

Factory default: 2000

P28 - - b a Echo loss indication

a	Echo loss indication	Remark
0	Delayed indication	<p>During short echo-loss (for the period of twice the time set in P20) analogue output will hold last value. After this period the current value according to the setting in P12 and via HART ERROR CODE 2 will be transmitted.</p>
1	No indication	For the time of echo-loss, analogue output will hold last value.
2	Filling simulation	Loosing echo during the filling process, transmitted value will increase according to the filling speed set in P26
3	Immediate indication	Loosing echo the current value (according to the setting in P12) and the ERROR CODE 2 (via HART) will immediately be transmitted.
4	Empty tank indication	Echo-loss may occur in completely empty tanks with a spherical bottom due to deflection of the ultrasonic beam, or in case of silos with an open outlet. In such cases it may be useful to indicate empty tank instead of echo loss.

Factory default: 10

P29 - - - - Blocking out of disturbing object

One fixed object in the tank, disturbing the measurement, can be blocked out. By the use of the Echo Map (P70) the precise distance of disturbing object can be read out. This value should be entered in this parameter.

Factory default: 0

P31: - - - - Sound velocity at 20°C (m/s or ft/s depending on P00(c))

This parameter should be used if the sound velocity in the gases above the measured surface differs largely from that of in the air. This is recommended for applications where the gas is more or less homogeneous. If it is not, the accuracy of the measurement can be improved using 32-point linearisation (P48, P49). *For sound velocities in various gases see section "Sound Velocities".*

Factory default: 343,8 (m/s)

P32: - - - - Specific gravity

Entering a value (other than "0") of specific gravity in this parameter, the weight will be displayed instead of VOL. Engineering unit should be [kg/dm³] or [lb/ft³] depending on P00 (c)

Factory default: 0

7.5 Volume (content) measurement

P40: --ba Tank shape

ba	Tank shape	Also to be set
b0	Standing cylindrical tank shape (value of "b" as below)	P40(b), P41
01	Standing cylindrical tank with conical bottom	P41, P43, P44
02	Standing rectangular tank (with chute)	P41, P42, (P43, P44, P45)
b3	Lying cylindrical tank shape (value of "b" as below)	P40(b), P41, P42
04	Spherical tank	P41

Attention:
The value „a“
determining the
shape of the tank
should be set first

Factory default: 00

P41-45: ---- Behälterabmessungen

Standing cylindrical tank
with hemispherical bottom
a=0

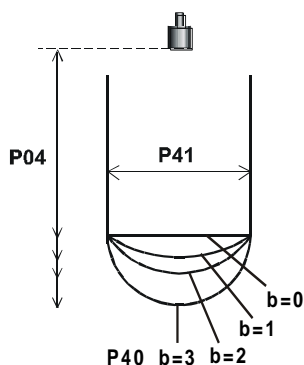

Standing cylindrical tank
with conical bottom
a=1 b=0

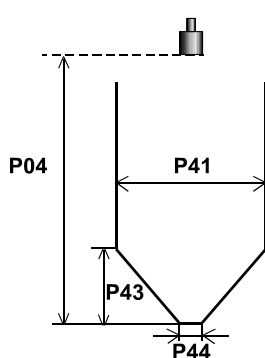

Standing rectangular tank
with or without chute
a=2 b=1

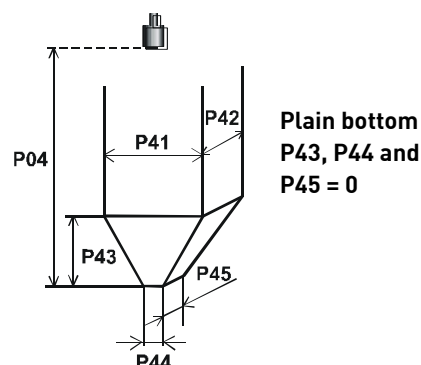

Plain bottom
P43, P44 and
P45 = 0

Lying cylindrical tank a = 3

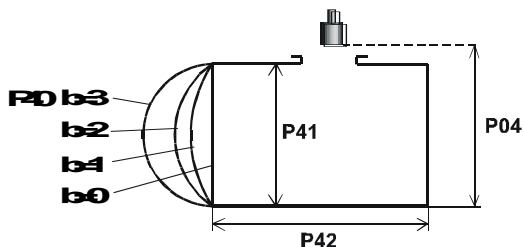

Spherical tank a = 4, b = 0

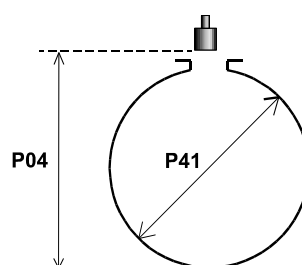

Factory default: 0

7.6 Open channel flow measurement

- ▶ The unit is suitable for open channel flow measurement with the constructive works
- ▶ For ultimate accuracy, install the sensor as close as possible above the expected maximum water level [see minimum measuring range].
- ▶ Install the unit in a place defined by the characteristics of the metering channel along the longitudinal axis of the flume or weir. In case of Parshall flumes the location of the sensor is marked.
- ▶ In some cases foam may develop on the surface. Make sure that the surface, opposite to the sensor, remains free of foam for proper sound reflection.
- ▶ The unit should be fixed so that it's position would not change.
- ▶ From measurement accuracy point of view the length of the channel sections preceding and following the measuring flume and their method of joining to the measuring channel section are of critical importance.
- ▶ Despite of the most careful installation, the accuracy of flow metering will be lower than that of specified for the distance measurement. The features of the flume or weir applied will determine it.
- ▶ Devices should be protected against overheating due to direct sunshine by using sunshades.

P40: - - b a Devices, formula, data

ba	Devices, formula, data						Also to be set
	Type	Formula	Qmin [l/s]	Qmax [l/s]	"P" [cm]		
00	Parshall channels	GPA-1P1	$Q [l/s] = 60.87 * h^{1.552}$	0.26	5.38	30	P46
01		GPA-1P2	$Q [l/s] = 119.7 * h^{1.553}$	0.52	13.3	34	P46
02		GPA-1P3	$Q [l/s] = 178.4 * h^{1.555}$	0.78	49	39	P46
03		GPA-1P4	$Q [l/s] = 353.9 * h^{1.558}$	1.52	164	53	P46
04		GPA-1P5	$Q [l/s] = 521.4 * h^{1.558}$	2.25	360	75	P46
05		GPA-1P6	$Q [l/s] = 674.6 * h^{1.556}$	2.91	570	120	P46
06		GPA-1P7	$Q [l/s] = 1014.9 * h^{1.556}$	4.4	890	130	P46
07		GPA-1P8	$Q [l/s] = 1368 * h^{1.5638}$	5.8	1208	135	P46
08		GPA-1P9	$Q [l/s] = 2080.5 * h^{1.5689}$	8.7	1850	150	P46
09	General PARSHALL flume						P46, P42
10	PALMER-BOWLUS (D/2)						P46, P41
11	PALMER-BOWLUS (D/3)						P46, P41
12	PALMER-BOWLUS (Rectangular)						P46, P41, P42
13	Khafagi Venturi						P46, P42
14	Bottom-step weir						P46, P42
15	Suppressed rectangular or BAZIN weir						P46, P41, P42
16	Trapezoidal weir						P46, P41, P42
17	Special trapezoidal (4:1) weir						P46, P42
18	V-notch weir						P46, P42
19	THOMSON (90°-notch) weir						P46
20	Circular weir						P46, P41
21	General flow formula: $Q[l/s] = 1000 * P41 * h^{P42}$, h [m]						P46, P41, P42

Factory default: 00

P41-45: Flume/weir dimensions

P40=00 **Parshall flumes (GPA1P1 ... GPA-1P9)**
 For further details see the Manual of the Parshall flume

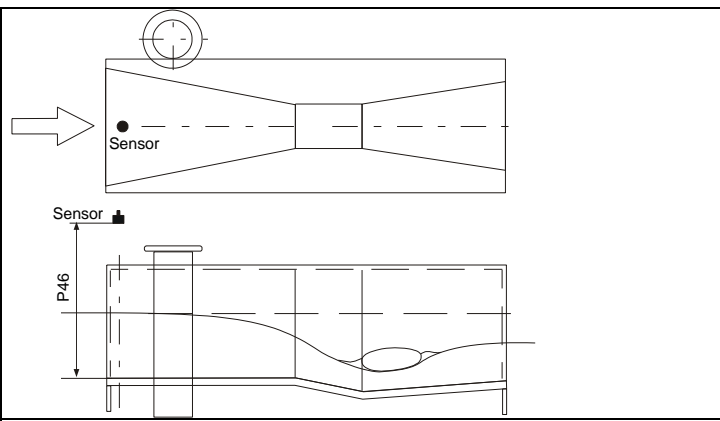

P40=09 **General Parshall flume**
 $0,305 < P42(\text{width}) < 2,44$
 $Q[l/s] = 372 \cdot P42 \cdot (h/0,305)^{1,569} \cdot P42^{0,026}$

P42 [m]	K
3,05	2,450
4,57	2,400
6,10	2,370
7,62	2,350
9,14	2,340
15,24	2,320

$2,5 < P42$
 $Q[m^3/s] = K \cdot P42 \cdot h^{1,6}$
 $P = 2/3 \cdot A$

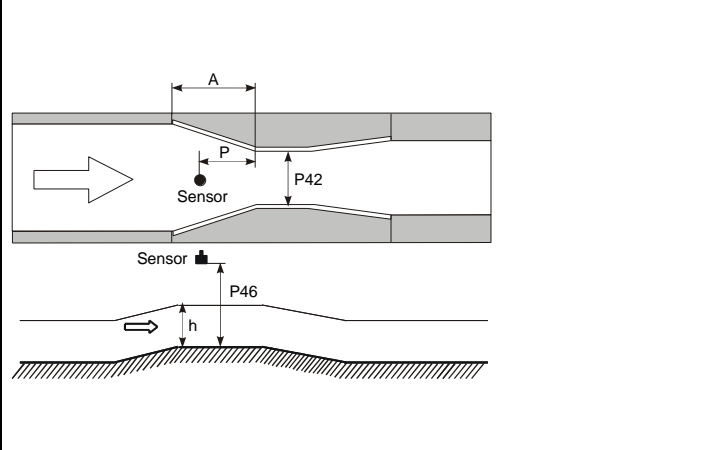

P40=10 **Palmer-Bowlus (D/2) flume**
 $Q[m^3/s] = f(h1/P41) \cdot P41^{2,5}$, where $h1[m] = h + (P41/10)$
 P41 [m]

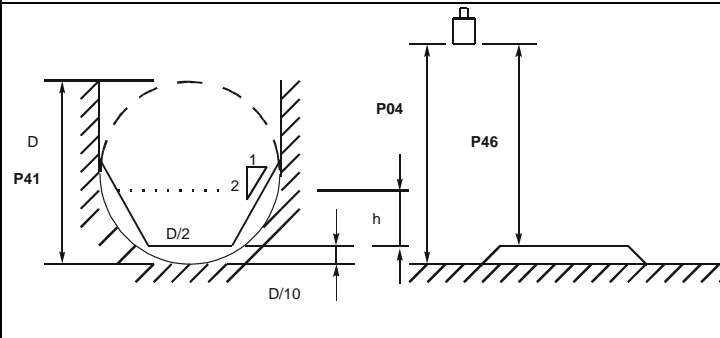

P40=11 **Palmer-Bowlus (D/3) flume**
 $Q[m^3/s] = f(h1/P41) \cdot P41^{2,5}$, wobei $h1[m] = h + (P41/10)$
 P41 [m]

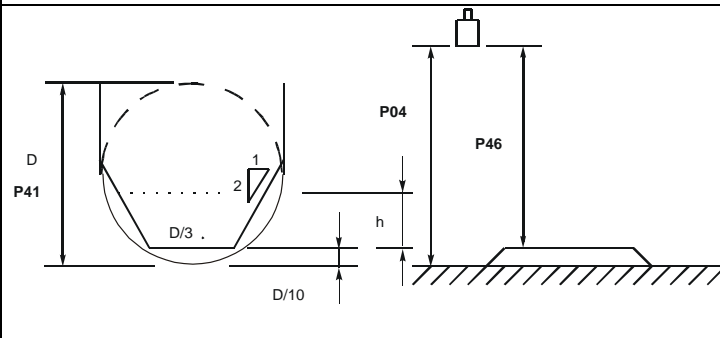

P40=12 **Palmer-Bowlus (rectangular) flume**
 $Q[m^3/s] = C \cdot P42 \cdot h^{1,5}$, where $C = f(P41/P42)$
 P41 [m], P42 [m]

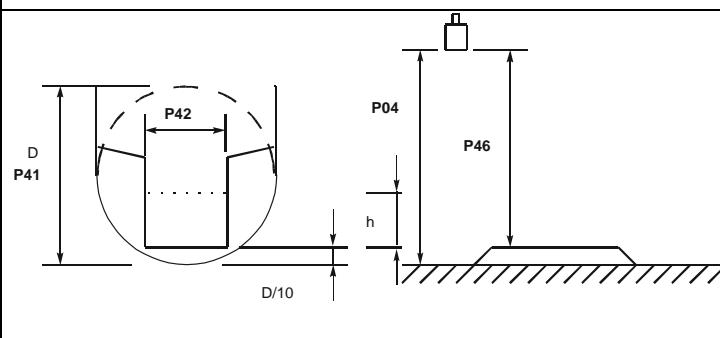

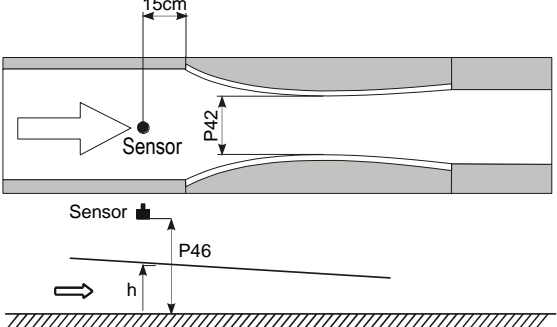
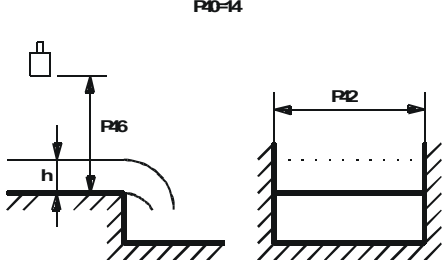
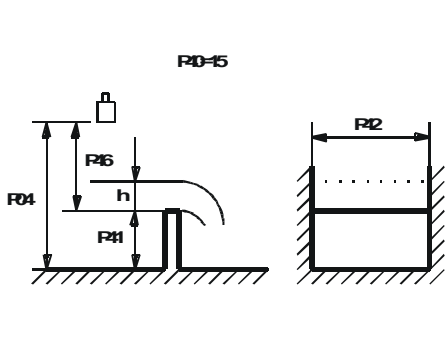
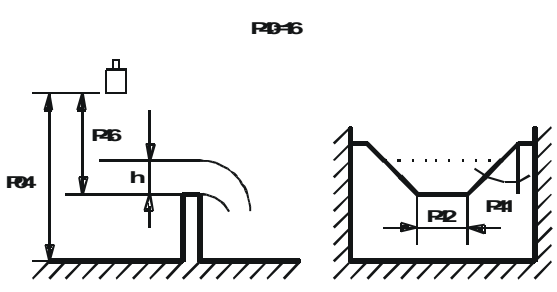
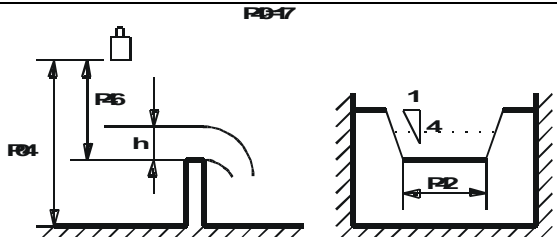
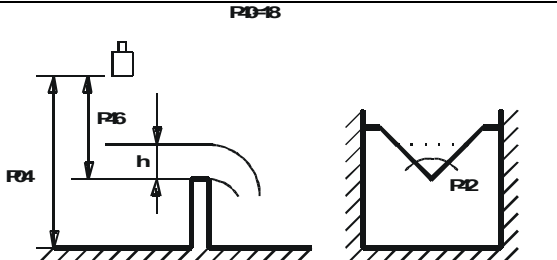
<p>P40= 13</p>	<p>Khafagi Venturi flume $Q [m^3/s] = 1,744 \cdot P42 \cdot h^{1,5} + 0,091 \cdot h^{2,5}$ P42 [m] h [m]</p>	
<p>P40= 14</p>	<p>Bottom step weir $0,0005 < Q [m^3/s] < 1$ $0,3 < P42 [m] < 15$ $0,1 < h [m] < 10$ $Q [m^3/s] = 5,073 \cdot P42 \cdot h^{1,5}$ Accuracy: $\pm 10\%$</p>	
<p>P40= 15</p>	<p>Suppressed rectangular or BAZIN weir $0,001 < Q [m^3/s] < 5$ $0,15 < P41 [m] < 0,8$ $0,15 < P42 [m] < 3$ $0,015 < h [m] < 0,8$ $Q [m^3/s] = 1,77738(1 + 0,1378h/P41) \cdot P42 \cdot (h + 0,0012)^{1,5}$ Accuracy: $\pm 1\%$</p>	
<p>P40= 16</p>	<p>Trapezoidal weir $0,0032 < Q [m^3/s] < 82$ $20 < P41 [^\circ] < 100$ $0,5 < P42 [m] < 15$ $0,1 < h [m] < 2$ $Q [m^3/s] = 1,772 \cdot P42 \cdot h^{1,5} + 1,320 \cdot \text{tg}(P41/2) \cdot h^{2,47}$ Accuracy: $\pm 5\%$</p>	
<p>P40= 17</p>	<p>Special trapezoidal (4:1) weir $0,0018 < Q [m^3/s] < 50$ $0,3 < P42 [m] < 10$ $0,1 < h [m] < 2$ $Q [m^3/s] = 1,866 \cdot P42 \cdot h^{1,5}$ Accuracy: $\pm 3\%$</p>	
<p>P40= 18</p>	<p>V-notch weir $0,0002 < Q [m^3/s] < 1$ $20 < P42 [^\circ] < 100$ $0,05 < h [m] < 1$ $Q [m^3/s] = 1,320 \cdot \text{tg}(P42/2) \cdot h^{2,47}$ Accuracy: $\pm 3\%$</p>	

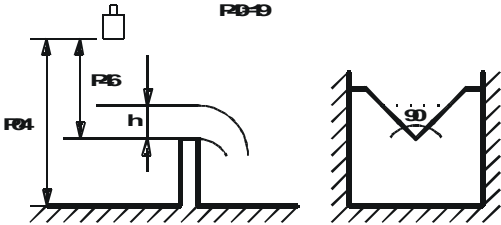
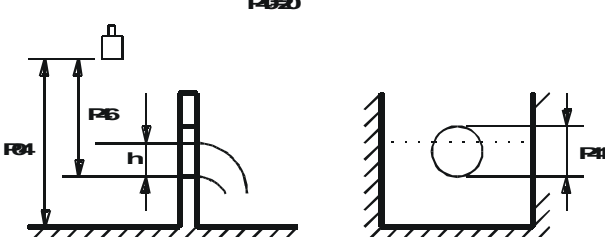
<p>P40= 19</p>	<p>THOMSON (90°-notch) weir $0,0002 < Q [m^3/s] < 1$ $0,05 < h [m] < 1$ $Q[m^3/s] = 1,320 \cdot h^{2,47}$ Accuracy:: $\pm 3\%$</p>	
<p>P40= 20</p>	<p>Circular weir $0,0003 < Q [m^3/s] < 25$ $0,02 < h [m] < 2$ $Q[m^3/s] = m \cdot b \cdot D^{2,5}$, where $b = f(h/D)$ $m = 0,555 + 0,041 \cdot h/P41 + (P41/[0,11 \cdot h])$ Accuracy:: $\pm 5\%$</p>	

Factory default: 0

P46: - - - - Distance at Q=0

Distance between sensor surface and the level at which flow starts has to be entered in this parameter.
 Factory default: 0

7.7 32-Point-Linearisation

P47: - - - a Linearisation

Linearisation is the method of assigning requested (calibrated or calculated) level, volume or flow to values measured by the transmitter. It can be used for instance if the sound velocity is not known (LEVEL⇒LEVEL) or in the case of tank with other shape than under 6.4 or open channel other than under 6.5 (LEVEL ⇒ VOLUME or LEVEL ⇒ FLOW).

a	Linearisation
0	OFF (FACTORY DEFAULT)
1	ON

Conditions of correct programming of the data pairs

- The table must always start with: L(1)= 0 and r(1)= value (assigned to 0 level)
- The table must be ended either with the 32nd data pair i.e. j=32 or if the linearisation table contains less than 32 data-pairs j<32, it must be ended with a level value "0" e.g. L[j<32]= 0.
- The 2270 Ultrasonic Level Transmitter will ignore data after recognising level value "0" with serial number other than "1".

If the above conditions are not met, error codes will be displayed (see chapter: Error Codes).

i	L (Left column) Level values measured	r (Right column) Value assigned to transmit
1	0	r(1)
2	L(2)	r(2)
	L(i)	r(i)
nn	L(nn)	r(nn)
nn+1	0	
32		

Factory default: 0

P48: Number of linearisation data pairs

Number of linearisation data pairs entered in the table.

7.8 Information parameters (read out parameters)**P60: - - - - Overall operating hours of the unit (h)****P61: - - - - Time elapsed after last switch-on (h)****P64: - - - - Actual temperature of the transducer (°C/°F)**

Broken loop of the thermometer will be indicated by display of the Pt Error message initiated by a signal sent via HART. In this case the transmitter will perform temperature correction corresponding to 20°C.

P65: - - - - Maximum temperature of the transducer (°C/°F)**P66: - - - - Minimum temperature of the transducer (°C/°F)****P70: - - - - Number of Echoes / Echo Map**

Amplitude and position of the echoes can also be read out.

P71: - - - - Distance of the of Measuring Window**P72 - - - - Amplitude of the selected echo [dB] <0****P73: Position of the selected echo (time) :(ms) [ms]****P74: Signal To Noise Ratio**

Ratio	Measurement conditions
Over 70	Excellent
Between 70 and 30	Good
Under 30	Unreliable

P75: - - - - Blocking Distance

The actual close-end blocking distance will be displayed (provided automatic blocking was selected in P05).

7.9 Additional parameters of the flow metering

P76: - - - - Head of flow (LEV) (Read only parameter)

The Headwater value can be checked here. This is the “h” value in the formula for flow calculation..

P77: - - - - TOT1 volume flow totalised (resettable)

P78: - - - - TOT2 volume flow totalised (non-resettable)

7.10 Other parameters

P96: - - - - Software Code 1 (Read only parameter)

P97: - - - - Software Code 2 (Read only parameter)

P98: - - - - Hardware Code (Read only parameter)

P99: - - - - Access lock by secret code

The purpose of this feature is to provide protection against accidental programming or intentional reprogramming of parameters by a person not entitled to do so. The secret code can be any value other than 0000. Setting a secret code will automatically be activated when the 2270 Ultrasonic Level Sensor is returned to the Measurement Mode. In order to program locked device the secret code should be entered first in P99. Thus for entering a new code or erasing the old one the knowledge of the previous code is necessary.

8. Maintenance

2270 Ultrasonic Level Sensor units do not require maintenance on a regular basis.

The need for cleaning of the sensor head may occur. Cleaning should be performed by utmost care where scraping or denting of the transducer have to be avoided.

Repair under or after the guarantee period should only be carried out by GF Piping Systems. Devices for repair should only be returned duly cleaned and disinfected.

9. Error codes

Error Code	Error description	Causes and solutions
1	Memory error	Contact representative of GF Piping Systems
2	Echo loss	No echo received (no reflection), see chapter „Indication of mistakes (by LEDs) made during programming”
3	Hardware error	Contact representative of GF Piping Systems
4	Display overflow	Check settings
5	Sensor error or improper installation/mounting, level in the dead band	Verify sensor for correct operation and check for correct mounting according to the User’s Manual
6	The measurement is at the reliability threshold	Better location should be found.
7	No signal received within the measuring range specified in P04 and P05	Check programming, also look for installation mistake
12	Linearisation table error: both L(1) and L(2) are zero (no valid data-pairs)	See “Linearisation” Section
13	Linearisation table error: same L(i) data is given twice in the table	See “Linearisation” Section
14	Linearisation table error: the r(i) values are not monotone increasing	See “Linearisation” Section
15	Linearisation table error: measured Level is higher than the last Volume or Flow data-pair	See “Linearisation” Section
16	The check sum of the program is wrong	Contact representative of GF Piping Systems
17	Parameter consistency failure	Check programming
18	Hardware failure	Check programming

10. Parameter table

Par.	Page	Description	Value				Par.	Page	Description	Value			
			d	c	b	a				d	c	b	a
P00	11	Application/ Engineering Units					P28	19	Echo loss indication				
P01	11	Measurement Mode					P29	19	Blocking out a disturbing object				
P02	11	Calculation units					P30		-				
P03		-					P31	19	Sound velocity values in different gases				
P04	13	Maximum Measuring Distance					P32	19	Specific gravity				
P05	14	Minimum Measuring Distance					P33		-				
P06	15	Fernausblendung					P34		-				
P07		-					P35		-				
P08		-					P36		-				
P09		-					P37		-				
P10	16	Transmitted value assigned to „4 mA”					P38		-				
P11	11	Transmitted value assigned to „20 mA”					P39		-				
P12	16	“Error” indication by the current output					P40	20	Selection of tank shape/ open channel				
P13		-					P41	22	Dimensions of tank / Open Channel				
P14		-					P42	22	Dimensions of tank / Open Channel				
P15		-					P43	22	Dimensions of tank / Open Channel				
P16		-					P44	22	Dimensions of tank / Open Channel				
P17		-					P45	22	Dimensions of tank / Open Channel				
P18		-					P46	24	Level pertaining to flow Q= 0				
P19		-					P47	24	Linearisation				
P20	17	Damping					P48	25	Linearisation table				
P21		-					P49		-				
P22	17	Dome top tank compensation					P50		-				
P23		-					P51		-				
P24	18	Target tracking speed					P52		-				
P25	18	Selection of Echo in the measuring window					P53		-				
P26	18	Level elevation rate					P54		-				
P27	18	Level descent rate					P55		-				

Par.	Page	Description	Value				Par.	Page	Description	Value				
			d	c	b	a				d	c	b	a	
P56		-						P78	26	TOT2 volume flow totalised				
P57		-						P79		-				
P58		-						P80		-				
P59		-						P81		-				
P60	25	Overall operating hours of the unit						P82		-				
P61	25	Time elapsed after last switch-on						P83		-				
P62		-						P84		-				
P63		-						P85		-				
P64	25	Actual temperature of the transducer						P86		-				
P65	25	Maximum temperature of the transducer						P87		-				
P66	25	Minimum temperature of the transducer						P88		-				
P67		-						P89		-				
P68		-						P90		-				
P69		-						P91		-				
P70	26	Echo Map						P92		-				
P71	25	Position of the measuring window						P93		-				
P72	25	Amplitude of the selected echo						P94		-				
P73	25	Position of the selected echo						P95		-				
P74	25	Signal / noise ratio						P96	26	Software code 1				
P75	25	Blocking distance value						P97	26	Software code 2				
P76	26	Water head of the flow						P98	26	Hardware code				
P77	26	TOT1 volume flow totalised						P99	26	Access lock by secret code				

11. Sound velocity values in different gases

The following table contains the sound velocity values of various gases measured at 20°C.

Gases	Formula	Sound Velocity (m/s)	Gases	Formula	Sound Velocity (m/s)
Acetaldehyde	C ₂ H ₄ O	252,8	Ethylene	C ₂ H ₄	329,4
Acetylene	C ₂ H ₂	340,8	Helium	He	994,5
Ammonia	NH ₃	429,9	Hydrogen sulphide	H ₂ S	321,1
Argon	Ar	319,1	Methane	CH ₄	445,5
Benzene	C ₆ H ₆	183,4	Methanol	CH ₃ OH	347
Carbon dioxide	CO ₂	268,3	Neon	Ne	449,6
Carbon monoxide	CO	349,2	Nitrogen	N ₂	349,1
Carbon tetrachloride	CCl ₄	150,2	Nitrogen monoxide	NO	346
Chlorine	Cl ₂	212,7	Oxygen	O ₂	328,6
Dimethyl ether	CH ₃ OCH ₃	213,4	Propane	C ₃ H ₈	246,5
Ethane	C ₂ H ₆	327,4	Sulphur hexafluoride	SF ₆	137,8
Ethanol	C ₂ H ₅ OH	267,3			

12. Article overview

Code	Type	Article description
159 300 155	2270-P-1B-4	Range 4 m, PP body, 4..20 mA 2-wire / HART, BSP thread
159 300 156	2270-P-1B-6	Range 6 m, PP body, 4..20 mA 2-wire / HART, BSP thread
159 300 162	2270-V-1B-4	Range 4 m, PVDF body, 4..20 mA 2-wire / HART, BSP thread
159 300 163	2270-V-1B-6	Range 6 m, PVDF body, 4..20 mA 2-wire / HART, BSP thread
159 300 169	2270-P-1N-4	Range 4 m, PP body, 4..20 mA 2-wire / HART, NPT thread
159 300 170	2270-P-1N-6	Range 6 m, PP body, 4..20 mA 2-wire / HART, NPT thread
159 300 176	2270-V-1N-4	Range 4 m, PVDF body, 4..20 mA 2-wire / HART, NPT thread
159 300 177	2270-V-1N-6	Range 6 m, PVDF body, 4..20 mA 2-wire / HART, NPT thread

13. Disposal

- ▶ Before disposing of the different material, separate it by recyclables, normal waste and special waste.
- ▶ Comply with local legal regulations and provisions when recycling or disposing of the product, the individual components and the packaging.
- ▶ Comply with National regulations, standards and directives.



WARNING

Parts of the product may be contaminated with medium which is detrimental to health and the environment and therefore cleaning is not sufficient!

Risk of personal and health injury caused by this medium.

Prior to the disposal of the product:

- ▶ Collect any medium which has escaped and dispose of it in accordance with the local regulations.
- ▶ Neutralize residues of media in the product.
- ▶ Separate materials (plastics, metals etc.) and dispose of them in accordance with the local regulations.

If you have questions regarding the disposal of your product, please contact your national GF Piping Systems representative.

Worldwide at home

Our sales companies and representatives ensure local customer support in over 100 countries

www.gfps.com

Argentina/Southern South America

Georg Fischer Central Plastics
Sudamérica S.R.L.
Buenos Aires, Argentina
Phone +54 11 4512 02 90
gfccentral.ps.ar@georgfischer.com
www.gfps.com/ar

Australia

George Fischer Pty Ltd
Riverwood NSW 2210 Australia
Phone +61 (0) 2 9502 8000
australia.ps@georgfischer.com
www.gfps.com/au

Austria

Georg Fischer
Rohrleitungssysteme GmbH
3130 Herzogenburg
Phone +43 (0) 2782 856 43-0
austria.ps@georgfischer.com
www.gfps.com/at

Belgium/Luxembourg

Georg Fischer NV/SA
1070 Bruxelles/Brüssel
Phone +32 (0) 2 556 40 20
be.ps@georgfischer.com
www.gfps.com/be

Brazil

Georg Fischer Sist. de Tub. Ltda.
04795-100 São Paulo
Phone +55 (0) 11 5525 1311
br.ps@georgfischer.com
www.gfps.com/br

Canada

Georg Fischer Piping Systems Ltd
Mississauga, ON L5T 2B2
Phone +1 (905) 670 8005
Fax +1 (905) 670 8513
ca.ps@georgfischer.com
www.gfps.com/ca

China

Georg Fischer Piping Systems Ltd
Shanghai 201319
Phone +86 21 3899 3899
china.ps@georgfischer.com
www.gfps.com/cn

Denmark/Iceland

Georg Fischer A/S
2630 Taastrup
Phone +45 (0) 70 22 19 75
info.dk.ps@georgfischer.com
www.gfps.com/dk

Finland

Georg Fischer AB
01510 VANTAA
Phone +358 (0) 9 586 58 25
Fax +358 (0) 9 586 58 29
info.fi.ps@georgfischer.com
www.gfps.com/fi

France

Georg Fischer SAS
95932 Roissy Charles de Gaulle Cedex
Phone +33 (0) 1 41 84 68 84
fr.ps@georgfischer.com
www.gfps.com/fr

Germany

Georg Fischer GmbH
73095 Albershausen
Phone +49 (0) 7161 302-0
info.de.ps@georgfischer.com
www.gfps.com/de

India

Georg Fischer Piping Systems Ltd
400 076 Mumbai
Phone +91 224007 2001
branchoffice@georgfischer.com
www.gfps.com/in

Italy

Georg Fischer S.p.A.
20063 Cernusco S/N (MI)
Phone +39 02 921 861
it.ps@georgfischer.com
www.gfps.com/it

Japan

Georg Fischer Ltd
556-0011 Osaka,
Phone +81 (0) 6 6635 2691
jp.ps@georgfischer.com
www.gfps.com/jp

Korea

Georg Fischer Piping Systems
271-3 Seohyeon-dong Bundang-gu
Seongnam-si, Gyeonggi-do
Seoul 463-824
Phone +82 31 8017 1450
Fax +82 31 8017 1454
kor.ps@georgfischer.com
www.gfps.com/kr

Malaysia

George Fischer [M] Sdn. Bhd.
40460 Shah Alam, Selangor Darul Ehsan
Phone +60 (0) 3 5122 5585
my.ps@georgfischer.com
www.gfps.com/my

Mexico/Northern Latin America

Georg Fischer S.A. de C.V.
Apodaca, Nuevo Leon
CP66636 Mexico
Phone +52 (81) 1340 8586
Fax +52 (81) 1522 8906
mx.ps@georgfischer.com
www.gfps.com/mx

Middle East

Georg Fischer
Piping Systems [Switzerland] Ltd
Dubai, United Arab Emirates
Phone +971 4 289 49 60
gcc.ps@georgfischer.com
www.gfps.com/int

Netherlands

Georg Fischer N.V.
8161 PA Epe
Phone +31 (0) 578 678 222
nl.ps@georgfischer.com
www.gfps.com/nl

New Zealand

Georg Fischer Ltd
13 Jupiter Grove, Upper Hutt 5018
PO Box 40399, Upper Hutt 5140
Phone +64 (0) 4 527 9813
nz.ps@georgfischer.com
www.gfps.com/nz

Norway

Georg Fischer AS
1351 Rud
Phone +47 67 18 29 00
no.ps@georgfischer.com
www.gfps.com/no

Poland

Georg Fischer Sp. z o.o.
05-090 Sekocin Nowy
Phone +48 (0) 22 31 31 0 50
poland.ps@georgfischer.com
www.gfps.com/pl

Romania

Georg Fischer
Piping Systems (Switzerland) Ltd
020257 Bucharest - Sector 2
Phone +40 (0) 21 230 53 80
ro.ps@georgfischer.com
www.gfps.com/int

Russia

Georg Fischer
Piping Systems (Switzerland) Ltd
Moscow 125047
Phone +7 495 258 60 80
ru.ps@georgfischer.com
www.gfps.com/ru

Singapore

George Fischer Pte Ltd
11 Tampines Street 92, #04-01/07
528 872 Singapore
Phone +65 6747 0611
sgp.ps@georgfischer.com
www.gfps.com/sg

Spain/Portugal

Georg Fischer S.A.
28046 Madrid
Phone +34 (0) 91 781 98 90
es.ps@georgfischer.com
www.gfps.com/es

Sweden

Georg Fischer AB
117 43 Stockholm
Phone +46 (0) 8 506 775 00
info.se.ps@georgfischer.com
www.gfps.com/se

Switzerland

Georg Fischer
Rohrleitungssysteme [Schweiz] AG
8201 Schaffhausen
Phone +41 (0) 52 631 30 26
ch.ps@georgfischer.com
www.gfps.com/ch

Taiwan

Georg Fischer Co., Ltd
San Chung Dist., New Taipei City
Phone +886 2 8512 2822
Fax +886 2 8512 2823
www.gfps.com/tw

United Kingdom/Ireland

Georg Fischer Sales Limited
Coventry, CV2 2ST
Phone +44 (0) 2476 535 535
uk.ps@georgfischer.com
www.gfps.com/uk

USA/Caribbean

Georg Fischer LLC
Tustin, CA 92780-7258
Phone +1 (714) 731 88 00
Toll Free 800 854 40 90
us.ps@georgfischer.com
www.gfiping.com

Vietnam

Georg Fischer Pte Ltd
136E Tran Vu, Ba Dinh District, Hanoi
Phone +84 4 3715 3290
Fax +84 4 3715 3285

International

Georg Fischer
Piping Systems [Switzerland] Ltd
8201 Schaffhausen/Switzerland
Phone +41 (0) 52 631 30 03
Fax +41 (0) 52 631 28 93
info.export@georgfischer.com
www.gfps.com/int

The technical data are not binding. They neither constitute expressly warranted characteristics nor guaranteed properties nor a guaranteed durability. They are subject to modification. Our General Terms of Sale apply.