



3-5075.090-1

Rev. E 3/06

English



**CAUTION!**

- Refer to this instruction manual for more details.
- Remove power to unit before wiring input and output connections.
- Follow instructions carefully to avoid personal injury.

**Contents**

- |  |  |
|--|--|
| <ol style="list-style-type: none"> <li>1. Power Connections</li> <li>2. Compatible Sensor Wiring</li> <li>3. Sensor Pulse Output Connections</li> <li>4. Auxiliary Pulse Output Connections</li> <li>5. Totalizer Reset Connections</li> </ol> | <ol style="list-style-type: none"> <li>6. Output Functions</li> <li>7. Menu Functions</li> <li>8. Parts and Accessories</li> <li>9. Specifications</li> <li>10. Quick Reference Menu Parameters</li> <li>11. Troubleshooting</li> <li>12. Maintenance</li> </ol> |
|--|--|

**Remove terminal blocks for easy wiring**

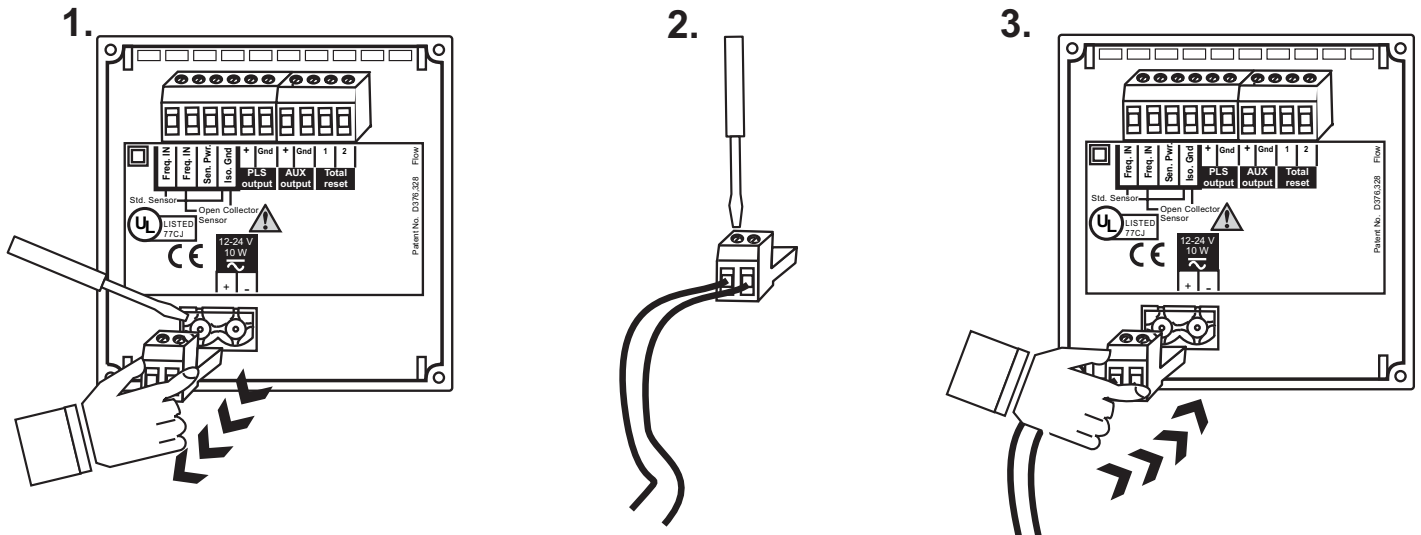

**1. Power Connections**



**CAUTION!** Never connect 115 VAC or 230 VAC to rear power terminals. High voltage AC will damage instrument and void warranty.

□ = Double Insulated  
 ~ = DC or AC power

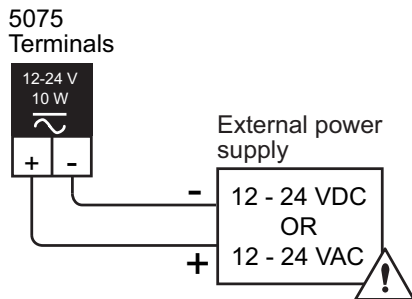

**2. Compatible Sensor Wiring**

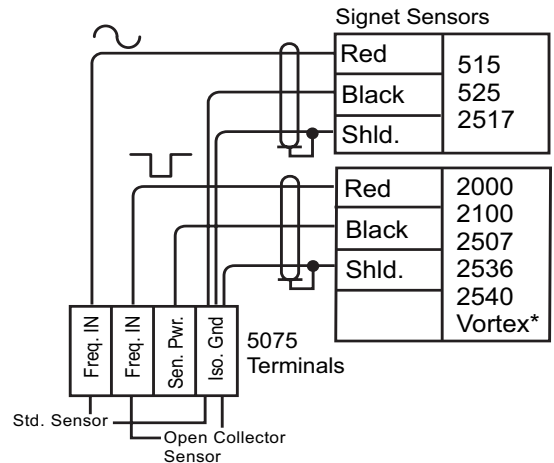

**Technical Notes:**

- To reduce the possibility of noise interference, route sensor cable away from AC power lines.
- \*Vortex sensor or system frequency output

### 3. Sensor Pulse Output Connections

3.1 Signet instrument **with** internal open-collector excitation voltage and pull-up resistor.

**Technical Notes:**

- Use 2-conductor shielded twisted-pair cable for output lines up to 30 m (100 ft.) max.
- Pull-up resistor **NOT REQUIRED** when connected to Signet instruments.

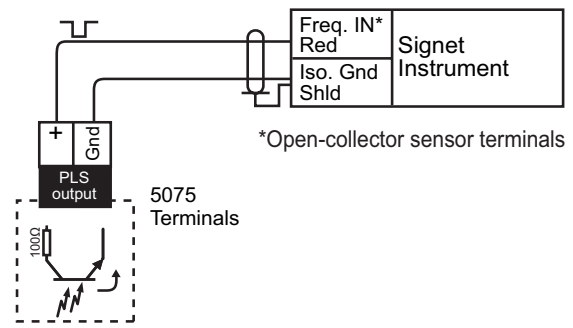

\*Open-collector sensor terminals

3.2 Pulse output connection options for instruments **without** internal open-collector excitation voltage and pull-up resistor shown below.

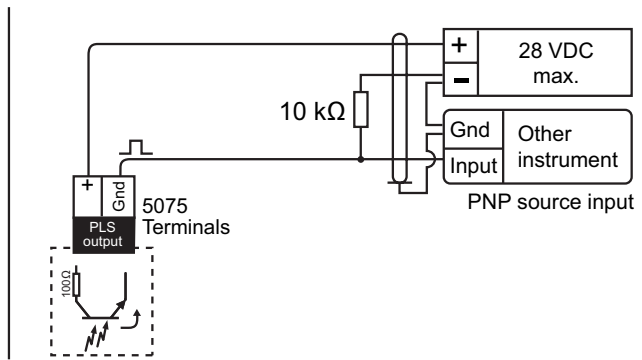
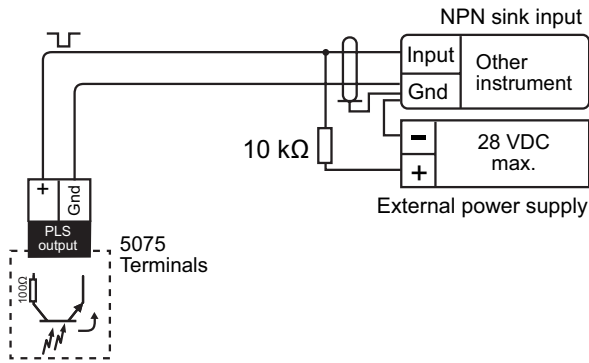

### 4. Auxiliary Pulse Output Connections

#### 4.1 Pulse mode - External device control

The auxiliary output can be configured for either TTL, CMOS, or open-collector compatible inputs using the proper pull-up resistor and an external power supply. Refer to recommendations below:

- **TTL inputs:** An external 5 VDC power supply and 10 kΩ pull-up resistor is recommended.
- **CMOS inputs:** An external 3 to 15 VDC power supply and 10 kΩ pull-up resistor is recommended.
- **12 VDC Open-collector inputs:** An external 12 VDC power supply and 10 kΩ pull-up resistor is recommended.
- **24 VDC Open-collector inputs:** An external 24 VDC power supply and 10 kΩ pull-up resistor is recommended.

**Technical Notes:**

- Open-collector transistor, optically isolated, 5 mA max. sink, 28 VDC max. pull-up voltage.
- Programmable pulse width, 0.10 - 999. seconds.
- Selectable Active high or active low pulse logic.
- Use 2-conductor **shielded twisted pair** cable for AUX output lines to 30 m (100 ft) max.

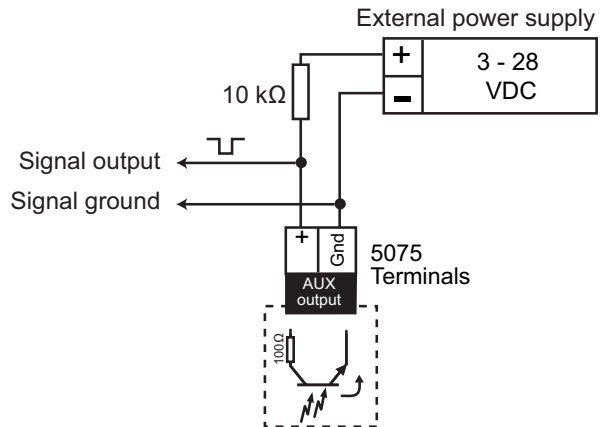

4.2 Totalizer pulse mode - External counter or accumulator inputs **without** internal open-collector excitation voltage and pull-up resistor.

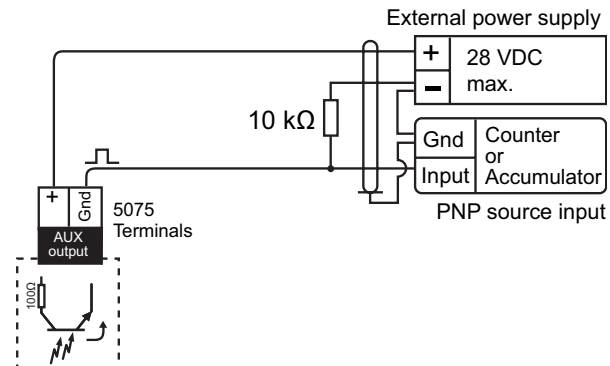
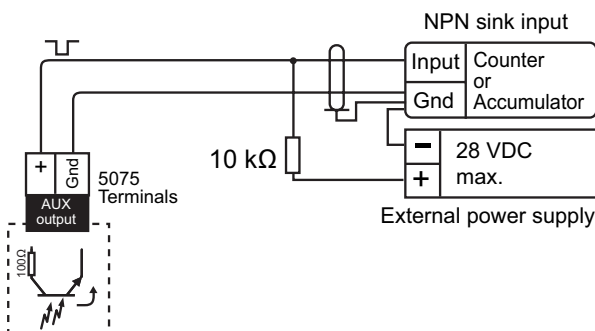

## 5. Totalizer Reset Connections

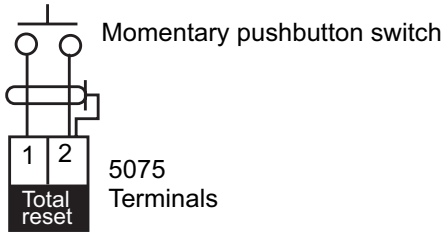

### Technical Notes:

- Use 2-conductor **shielded twisted pair** cable for reset lines up to 30 m (100 ft.) max. External reset switch overrides software security feature.
- To reduce the possibility of AC noise interference, isolate AC power lines from reset lines.

## 6. Output Functions

This section gives a detailed description of all 5075 output functions.

**6.1 Sensor pulse output:** This output emits an open-collector frequency equal to the sensor input. The output connects directly to a second Signet instrument for expanded process control with a single sensor input. The output is an open-collector type that requires an external pull up resistor and power supply for other instrument inputs.

**6.2 Auxiliary pulse output:** The auxiliary output can be configured as Low alarm, High alarm, Pulse or Totalizer output. Output logic can be selected for either active low (factory default) or active high operation. The auxiliary output is an open-collector type that requires an external pull-up resistor and power supply to operate.

### • LOW alarm mode

The output is active when the flow falls below the setpoint, and is inactive when the flow rises above the setpoint plus hysteresis.

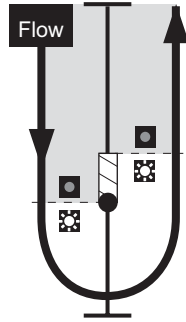
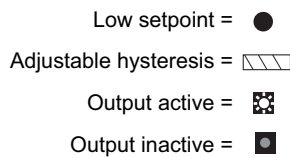

### • HIGH alarm mode

The output is active when the flow rises above the setpoint, and is inactive when the flow falls below the setpoint plus hysteresis.

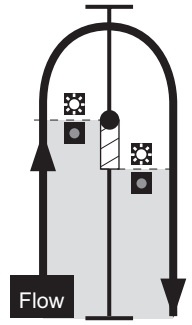
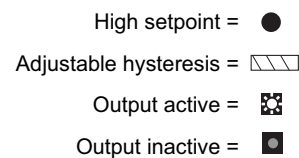

### • PULSE mode

The output is active for the programmed pulse width each time the programmed pulse volume is measured by the flow sensor.

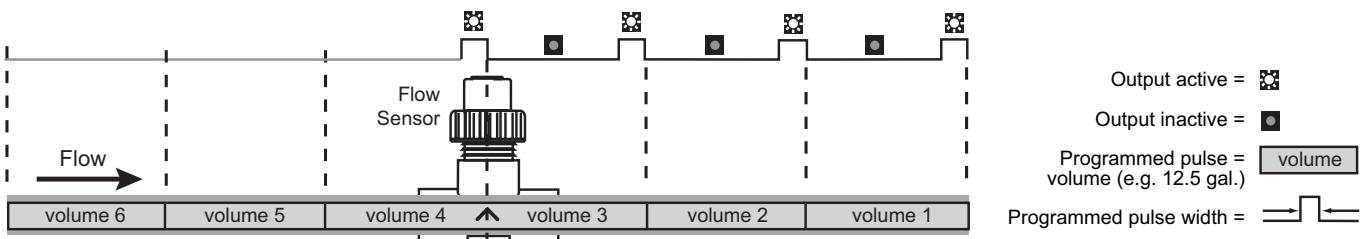

### • Totalizer function

The output emits an adjustable signal pulse width for each **whole** engineering unit measured by the flow sensor (also displayed on totalizer). To enable the totalizer function, the relay or auxiliary pulse volume must be set to 1.0000.



**6.3 Totalizer reset:** This feature allows the totalizer to be reset with a dry switch contact closure at any time. The external reset switch overrides software security feature.

## 7. Menu Functions

To access either CALIBRATE or OPTIONS menus, press and hold the ENTER key.

- **VIEW menu:** The VIEW menu is displayed during standard operation. The operator can navigate through the menu by pressing UP or DOWN arrow keys. The VIEW menu also offers a resettable totalizer feature that allows the operator to reset the displayed total.
- **CALIBRATE Menu:** The CALIBRATE menu contains critical display setup and output parameters. A security code feature prevents unauthorized tampering. An access code is necessary for menu access. The same code also unlocks OPTIONS menus.
- **OPTIONS Menu:** The OPTIONS menu contains setup and display features that are accessed for minor display or output adjustments.

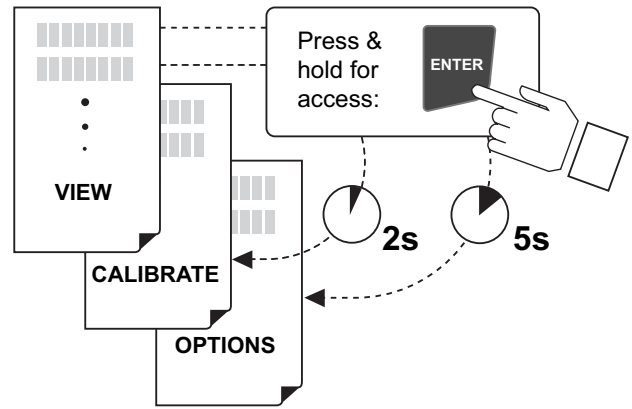

### 7.1 VIEW Menu

#### Menu Displays A - E:

(Factory default displays shown in menu column 1)

- A. Flowrate and resettable total display:** can be reset by the front panel keypad or by remote reset switch. An access code feature prevents accidental total reset, when enabled. External reset switch inputs override security feature, when enabled.
- B. Permanent total display:** records volumetric flow total for the life of the product and is non-resettable.
- C. Flow Range display:** shows the programmed min and max meter range.
- D. Aux output display:** this display shows the programmed operation mode and setpoint for the auxiliary output.
- E. Last calibration:** this display shows a user defined setup date for maintenance records. This feature is not an internal timer or calendar.

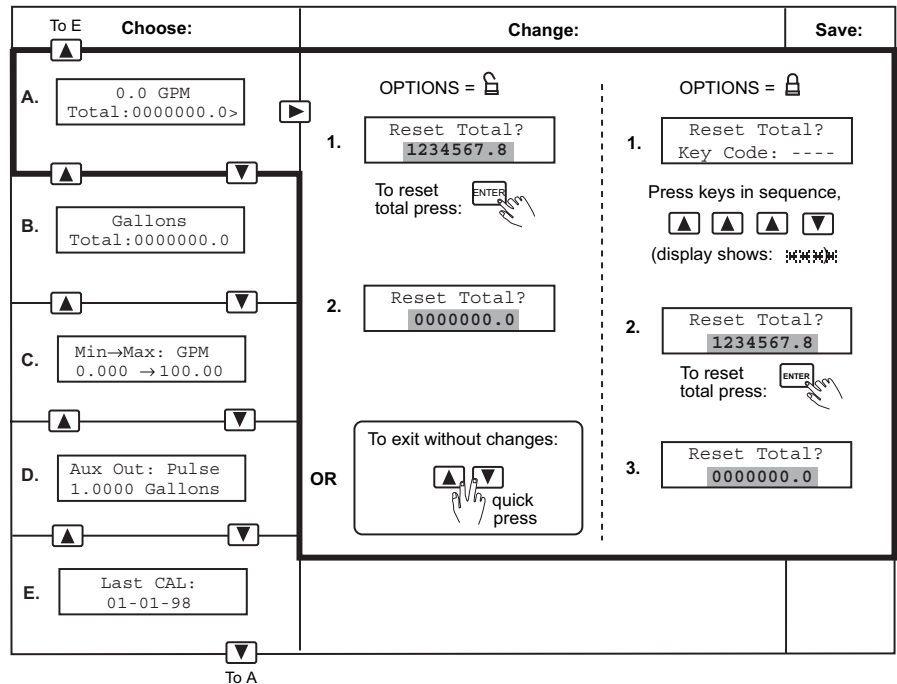

## 7.2 CALIBRATE Menu

Press and hold ENTER key for 2 seconds:

CALIBRATE: ----  
Enter Key Code is displayed.

Press keys in sequence to enter menu:

▲▲▲▼

CALIBRATE: XXXX  
Enter Key Code is displayed.

### Menu Settings A - J:

(Factory default displays shown in menu column 1)

- A. Sets flow units label (**gpm**) and timebase (**gpm**). Flow units label: Aa - Zz, 0 - 9, / Timebase options: h = hours, m = minutes, s=seconds, d = days
- B. Sets Min→Max meter and dial range, 00.000 to 99999.
- C. Sets flow K-Factor: 0.0001 to 99999. (see technical notes below)
- D. Sets 8-digit totalizer units label: Aa - Zz, 0 - 9, / (does not affect totalizer display or outputs)
- E. Sets totalizer K-Factor: 0.0001 to 99999. (see technical notes below)
- F. Sets auxiliary output mode Low or High, and flow rate setpoint, 0.0000 - 99999.
- G. Sets auxiliary output hysteresis, 0.0000 - 99999. (Set to zero to disable hysteresis feature)
- H. Sets auxiliary output pulse volume setpoint, 0.0001 - 99999. Set to 1.0000 (factory default) to enable totalizer function.
- I. Sets auxiliary output pulse width, 0.10 - 999. seconds.
- J. Sets user defined setup date for maintenance records. This feature is not an internal timer or calender.

To J	Choose:	Change:	Save:
▲	A. Flow Units: GPM >	Flow Units: GPM	Flow Units: mL/m ▲▼▶
▲▼	B. Min→Max: GPM 0.000→100.00 >	Min→Max: GPM 00.000→100.00	Min→Max: GPM 00.000→500.00 ▲▼▶
▲▼	C. Flow K-Factor: 60.000 >	Flow K-Factor: 60.000	Flow K-Factor: 32.480 ▲▼▶
▲▼	D. Total Units: Gallons >	Total Units: Gallons	Total Units: Gal x 10 ▲▼▶
▲▼	E. Total K-Factor: 60.000 >	Total K-Factor: 60.000	Total K-Factor: 324.80 ▲▼▶
<b>Aux Output Low or High Mode Selected</b>			
▲▼	F. Aux Out: Low 1.0000 GPM >	Aux Out: Low 1.0000 GPM	Aux Out: Low 10.500 GPM ▲▼▶
Mode (top row) Setpoint (bottom row)			
▲▼	G. Aux Out Hys: 0.0000 GPM >	Aux Out Hys: 0.0000 GPM	Aux Out Hys: 1.5000 GPM ▲▼▶
<b>Open-Collector Output Frequency Selected</b>			
▲▼	H. Aux Out: Pulse 1.0000 Gallons >	Aux Out: Pulse 1.0000 Gallons	Aux Out: Pulse 125.00 Gallons ▲▼▶
Mode (top row) Divisor (bottom row)			
▲▼	I. AuxOut PlsWidth: 0.10 Seconds >	AuxOut PlsWidth: 0.10 Seconds	AuxOut PlsWidth: 0.25 Seconds ▲▼▶
Mode (top row) Divisor (bottom row)			
▲▼	J. Last CAL: 01-01-99 >	Last CAL: 01-01-98	Last CAL: 02-05-98 ▲▼▶
To return to VIEW menu: ▲▼ quick press		To restore original value: Or press keys a second time to exit menu: ▲▼ quick press	



"SAVING" displayed

### Technical Notes:

The flow and total K-Factors are independent of each other. The K-Factor settings represent the number of pulses generated by the Signet flow sensor for each engineering unit of fluid measured (published in flow sensor manual).

## 7.3 OPTIONS Menu

Press and hold ENTER key for 5 seconds:

OPTIONS: ----  
Enter Key Code is displayed.

Press keys in sequence to enter menu:

▲▲▲▼ is displayed.  
OPTIONS: XXXX  
Enter Key Code is displayed.

### Menu Settings A - F:

(Factory default displays shown in menu column 1)

- A. Selects LCD display contrast: 5 levels
- B. Selects flow display decimal: \*\*\*\*. to \*\*.\*\*\*
- C. Selects totalizer display decimal: \*\*\*\*\*. to \*\*\*\*\*. \*\*
- D. Selects LCD display averaging: Off = 0 seconds, Low = 4 seconds, High = 8 seconds
- E. Selects totalizer reset options: Lock "Off" disables the VIEW menu access code feature, Lock "On" enables the feature. When enabled, an access code must be entered for totalizer reset privileges. The totalizer will be reset in either case if a contact closure is detected at rear reset terminals.
- F. Selects Auxiliary output logic: (See diagram)

- Active Low logic (factory default): Output changes from high to low when active.
- Active high logic: Output changes from low to high when active.

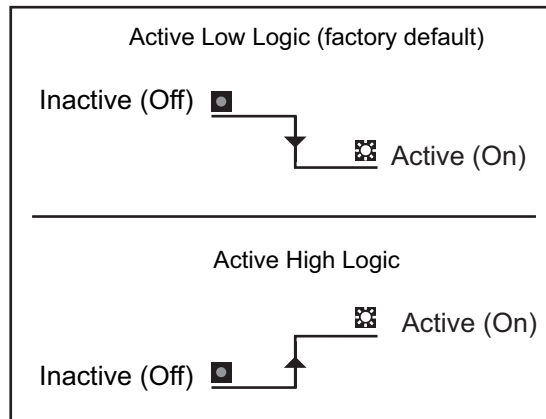
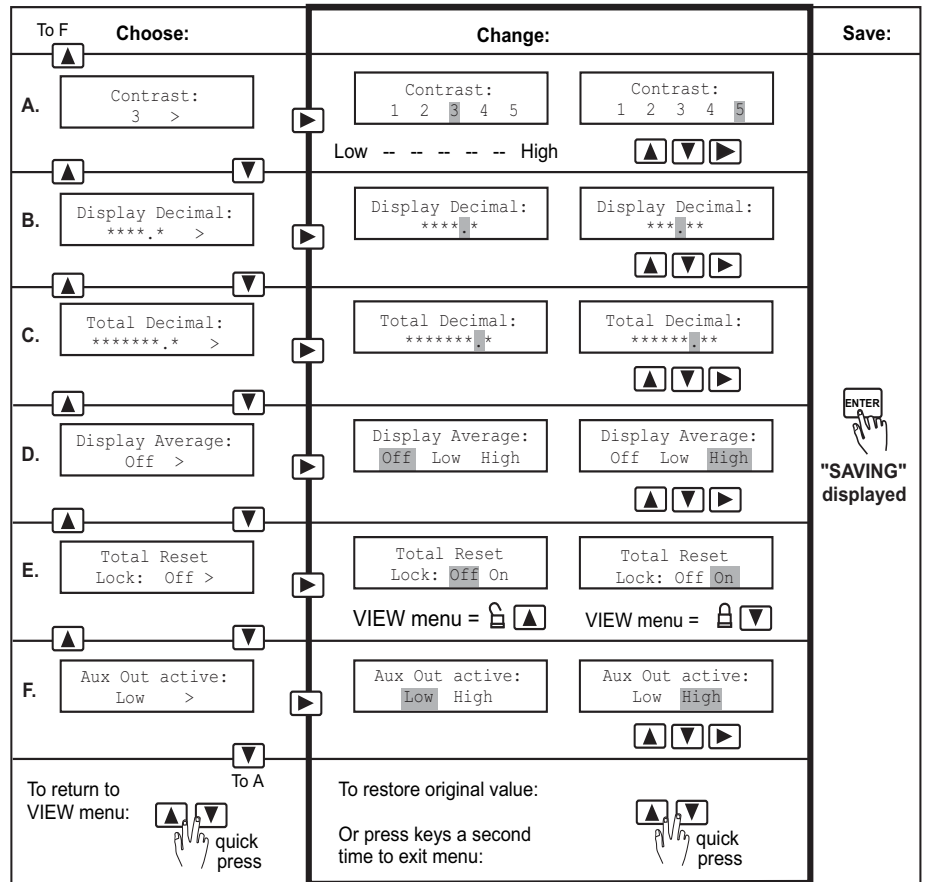

## 8. Parts and Accessories

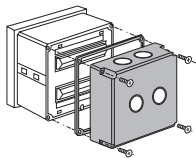

Splashproof rear cover  
3-5000.395 (code 198 840 227)

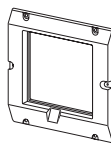

5 x 5 inch adapter plate for Signet retrofit  
3-5000.399 (code 198 840 224)

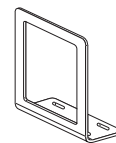

Optional surface mount bracket  
3-5000.598 (code 198 840 225)

- Power supply, 115 VAC - 24 VAC, 3-5000.075
- Front snap-on bezel, 3-5000.525 (code 198 840 226)
- Assorted flow unit/multiplier decals, 3-5500.612 (code 198 840 230)
- 5075 Instruction Manual 3-5075.090-1 (code 159 000 078)

## 9. Specifications

### General

Sensor compatibility: All Signet flow sensors  
 Accuracy:  $\pm 0.5\%$  of reading  
 Input: Optically isolated, 0.5 Hz to 10KHz  
 minimum amplitude 80 mV

### Enclosure:

- Rating: NEMA 4X/IP65 front
- Dimensions: 1/4 DIN, 96 x 96 x 88 mm (3.8 x 3.8 x 3.5 in.)
- Case materials: ABS plastic
- Keypad material: Sealed 4-key silicone rubber
- Weight: Approximately 500 g (18 oz.)

### Display:

- Type: Microprocessor controlled air-core meter movement and backlit alphanumeric 2 x 16 LCD
- Update rate: Flow = 1s, totalizer = <200 ms
- Contrast: User selected, 5 levels

### Totalizers:

- 8-digit resettable with security option
- 8-digit non-resettable

### Environmental

Operating temp.: -10 to 55°C (14 to 131°F),  
 50°C (122°F) max. with optional rear cover  
 Storage temp.: -15 to 80°C (5 to 176°F)  
 Relative humidity: 0 to 95%, non-condensing  
 Altitude: 4000 m max.  
 Pollution degree: 2

### Agency Approvals

- CE, UL listed
- Manufactured under ISO 9001

### Electrical

#### Power:

- 12 to 24 VDC or 12 to 24 VAC, unregulated, 50-60 Hz, 10 W max.

#### Sensor (PLS) Auxiliary (AUX) pulse outputs:

- Open-collector transistor, optically isolated, 5 mA max. sink, 28 VDC max. pull-up voltage, programmable (AUX) pulse width

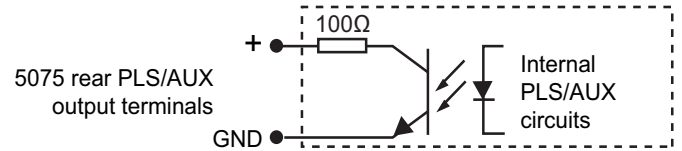

#### Totalizer reset:

- Front keypad or external contact closure, 30 m (100 ft) max. cable length
- External contact closure overrides security feature

Noise immunity: EN50082-2  
 Noise emissions: EN55011  
 Safety: EN61010-1

### Dimensions

#### Front View

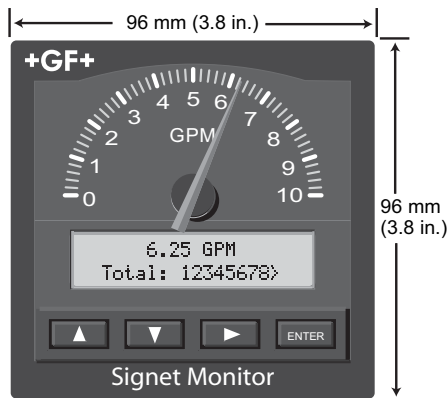

#### Side View

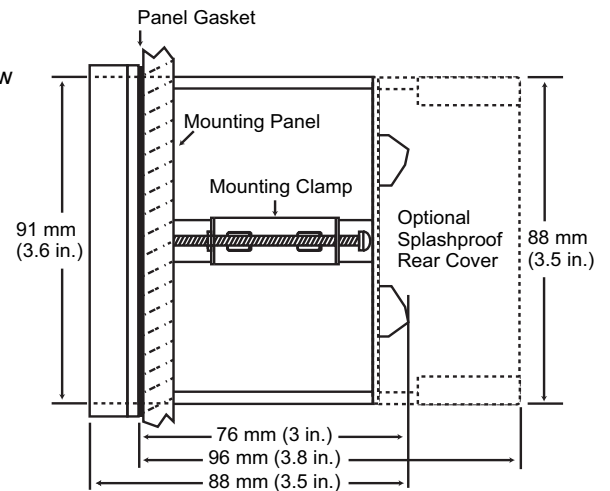

#### Rear View

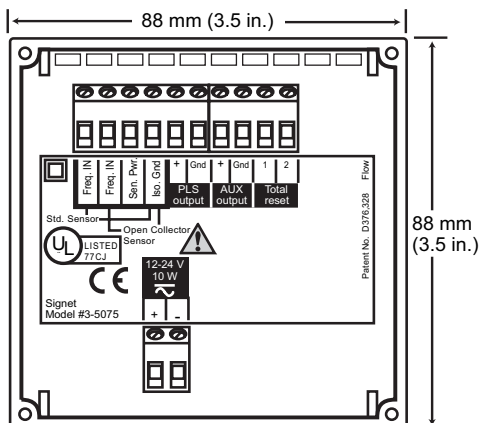

#### Panel Cutout

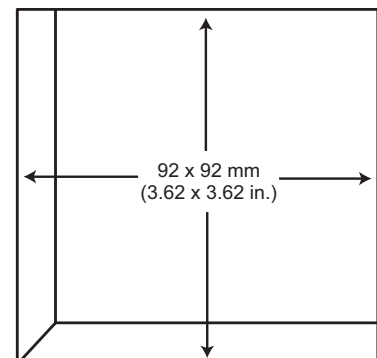

## 10. Quick Reference Menu Parameters

### VIEW Menu Setup Parameters

Menu Parameters	Display Description	Range	Factory Default
A. 0.0 GPM Total:0000000.0>	<ul style="list-style-type: none"> <li>Flow rate and units</li> <li>Resettable total</li> </ul>	00.000 - 99999. GPM 000000.00 - 99999999.	0000.0 0000000.0
B. Gallons Total:0000000.0	Permanent total	000000.00 - 99999999.	0000000.0
C. Min-Max: GPM 0.000 → 100.00	Min→Max meter and dial range	00.000 - 99999.	0.000 - 100.00
D. Aux Out: Pulse 1.0000 Gallons	<ul style="list-style-type: none"> <li>Aux output mode</li> <li>Aux output setpoint</li> </ul>	Low or High, 0.0000 - 99999. Pulse, 0.0001 - 99999.	Pulse 1.0000 Gallons
E. Last CAL: 01-01-98	Last calibration date	00 - 00 - 00 to 39 - 39 - 99	01 - 01 - 98

### CALIBRATE Menu Setup Parameters

Menu Parameters	Display Description	Range	Factory Default
A. Flow Units: GPM >	flow unit= digits 1-3 flow timebase= digits 4	Aa - Zz, 0 - 9, /, /, _; Mm, Ss, Hh, Dd	_GPM
B. Min-Max: GPM 0.000-100.00 >	Min→max range	00.000 - 99999.	00.000 - 100.00 GPM
C. Flow K-Factor: 60.000 >	Flow K-Factor	0.0001 - 99999.	60.000
D. Total Units: Gallons >	Total units	Aa - Zz, 0 - 9, /, /, _ (8-digits max.)	_Gallons
E. Total K-Factor: 60.000 >	Total K-Factor	0.0001 - 99999.	60.000
F. Aux Out: Low 1.0000 GPM>	<ul style="list-style-type: none"> <li>Aux output mode</li> <li>Aux output setpoint</li> </ul>	Low or High 0.0000 - 99999.	Low 1.0000
G. Aux Out Hys: 0.0000 GPM>	Aux output hysteresis volume	0.0000 - 99999.	0.0000
H. Aux Out: Pulse 1.0000 Gallons >	<ul style="list-style-type: none"> <li>Aux output mode</li> <li>Aux output setpoint</li> </ul>	Pulse 0.0001 - 99999.	1.000 Gallons
I. AuxOut PlsWidth: 0.10 Seconds >	Aux output pulse width	0.10 - 999. seconds	0.10 seconds
J. Last CAL: 01-01-98 >	Last calibration date	00 - 00 - 00 to 39 - 39 - 99	01 - 01 - 98

\_ = blank display digit option



## OPTIONS Menu Setup Parameters

Menu Parameters	Display Description	Range	Factory Default
A. Contrast: 3	Display contrast	0 to 5	3
B. Display Decimal: ****.*	Flow decimal	**.*** to ****.*	****.*
C. Total Decimal: *****.*	Totalizer decimal	*****.* to *****.*	*****.*
D. Display Average: Off >	Display averaging	Off = 0 sec., Low = 4sec., High = 8 sec.	Off
E. Total Reset Lock: Off >	VIEW menu total reset access code	On or Off	Off
F. Aux Out active: Low >	Auxiliary (AUX) output pulse logic	Active Low or Active High	Low

## 11. Troubleshooting

Display	Problem	Solution
--- ---	Display timebase too large	Change flow timebase (S = Seconds, M = Minutes, H = Hours, D = Days) in CALIBRATE menu to a smaller value (e.g. GPD to GPM)
Check settings for AUX output	Auxiliary output pulse width too large for frequency input or pulse volume too small.	Reduce auxiliary output pulse width setting or increase pulse volume setting
Must be between 0.0001 - 99999	Relay 1, Relay 2, or Auxiliary output (AUX) pulse volume setpoint must be within 0.0001 - 99999	Enter volumetric setpoint within 0.0001 - 99999. engineering units
Must be between 0.10 - 999	Relay 1, Relay 2, or Auxiliary output (AUX) pulse width must be within 0.10 - 999 seconds	Enter pulse width within 0.10 - 999 seconds
Flow K-Factor cannot be zero	Flow display K-Factor cannot be zero	Enter K-Factor greater than zero
Total K-Factor cannot be zero	Totalizer K-Factor cannot be zero	Enter K-Factor greater than zero
SETUP READ ERROR Press any key	Power fault occurred while saving setup menu entry	Press any key to reload factory defaults then reprogram flow system setup parameters. Note: totalizer displays remain undisturbed and will resume after instrument reset.

## 12. Maintenance

Clean the instrument case and front panel with a soft cloth and mild liquid soap solution.