

Signet 2714-2717 Twist-Lock pH/ORP Electrodes +GF+

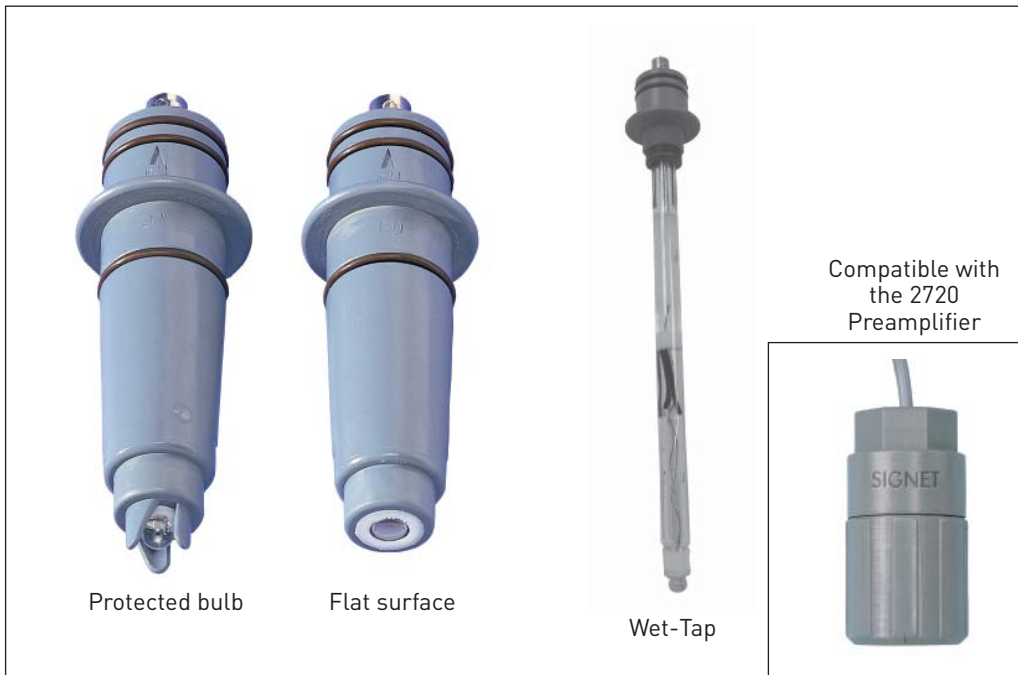

Features

- Durable CPVC or glass body with Twist-Lock connector
- Flat or bulb surfaced electrodes available
- Large reference volume and solid polymer electrolyte
- Integrated temperature sensor (pH)
- Designed for maximum protection from process contamination
- DI option (pH) for pure water use (<100 µS)
- HF option (pH) for applications containing trace amounts of HF (<2%)

Description

Feature-packed Signet 2714-2717 Twist-Lock pH & ORP Electrodes provide unsurpassed simplicity, reliability and accuracy for a wide variety of industrial applications. Rugged construction, large reference volume and intelligent positioning of internal elements combine to extend the service-life of these dependable and highly responsive electrodes. Flat versions allow sediment and particles to sweep past the measurement surface,

minimizing risks of abrasion, breakage and coating. The unique Twist-Lock design enables sensor connections to the Signet 2720 preamplifier in one easy motion. The integral temperature sensor built into the pH electrode or the I.D. resistor in the ORP electrodes is used for automatic sensor recognition by Signet pH/ORP instrumentation, adding convenience and versatility to our systems.

System Overview

In-Line Installation		Submersible Installation	Wet-Tap Installation
Panel Mount Signet Instrument (sold separately) 5700 8750	Pipe, Tank, Wall Mount Signet pH/ORP Transmitter (sold separately) Signet Universal Adapter Kit (3-8050) (sold separately) 	Panel, Pipe, Tank, Wall Mount Signet Instrument (sold separately) 5700 8750	Panel, Pipe, Tank, Wall Mount Signet Instrument (sold separately) 5700 8750
Signet 2714-2717 pH/ORP Electrode with 2720 Preamplifier (each sold separately) 	Signet 2714-2717 pH/ORP Electrode with 2720 Preamplifier (each sold separately) 	Pipe extension or conduit with 3/4 in. NPT or ISO 7/1-R 3/4 threads (customer supplied) 	Signet 2716-WT 2717-WT and 2720 preamp. (sold separately)
Signet sensor cap (sold separately) 		Signet 2714-2717 pH/ORP Electrode with Signet 2720 Preamplifier 	Signet 3719 WetTap Assembly (sold separately)
Signet Fittings* (sold separately) 			

* See Fittings section for more information.

Applications

- Water & Wastewater Treatment
- Neutralization Systems
- Effluent Monitoring
- Sanitization Systems
- Commercial Pools & Spas
- Aquatic Animal Life Support Systems
- Process Control
- Cooling Towers
- Boiler Protection



Specifications (continued)

2720 pH/ORP Preamp

General

Input Range: $\pm 2,500$ mV
 Power Requirements:
 ± 4.5 to ± 8 VDC, dual supply (provided by all Signet pH/ORP instruments)
 Maximum Current: < 1 mA, dual supply
 Temp. Contact Resistivity: $< 0.1\Omega$
 Input Impedance: $> 10^{11}\Omega$
 Gain: Unity
 End Connection: Twist-Lock mount to Signet 271X Electrodes
 Cable Type:
 6 conductor, foil shield, w/drain wire, 24AWG
 Cable Length:
 4.6 m (15 ft.) supplied; maximum extension to 120 m (400 ft.)

Wetted Material: CPVC

Max. Temperature/Pressure Rating

Operating Temperature:
 • 7 bar (100 psi) max @ 65°C (149°F)
 • 4 bar (58 psi) max @ 80°C (176°F)
 Storage Temperature:
 0°C to 80°C (32°F to 176°F)

See Temperature and Pressure graphs for more information.

Shipping Weight: 0.5 kg/1.2 lbs.

Standards and Approvals

- CE
- Manufactured under ISO 9001:2000 for Quality and ISO 14001:2004 for Environmental Management

2721 Remote pH/ORP Preamp

General

Input power:
 ± 4.5 to ± 8 VDC dual supply (provided by Signet pH/ORP instruments)
 Compatibility: pH sensors with cables and BNC connector (supplied by other manufacturers)
 Input Impedance: $> 10^{11}\Omega$
 Gain: Unity
 Current consumption: < 1 mA, dual supply
 Electronics assembly:
 Epoxy encapsulated

Material:

Housing: Low density polyethylene

Max. Temperature/Pressure Rating

Operating temperature:
 -15°C to 65°C (-5°F to 150°F)



2720 Preamp

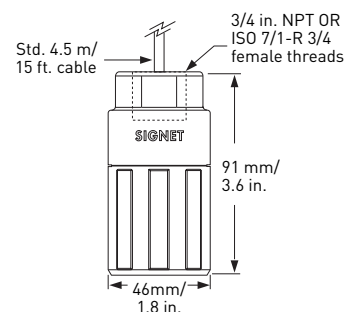

2714-2717 w/2720 Preamp 2714-2717 w/2720 Preamp with sensor cap

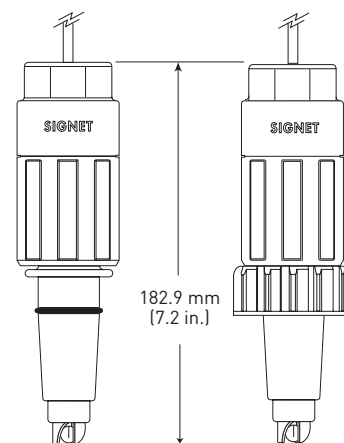

2716/17-WT w/ 2720 preamplifier in 3719 WetTap assembly

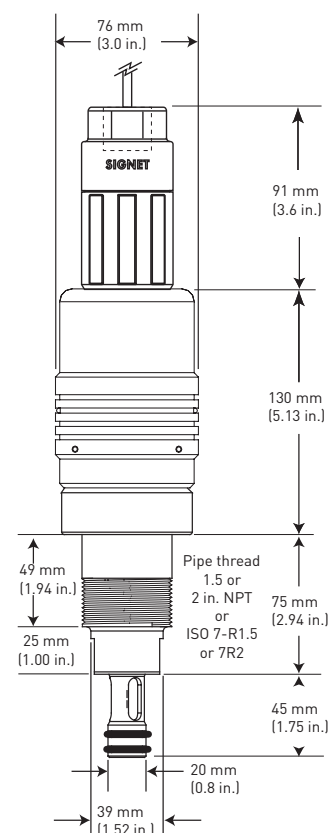

2721 Remote Preamp

The 2721 remote preamp should be used with special order sensors that are built with cables (Signet Models 277X-HT, 277X-1-HT, or other Signet sensors ordered with cables). It can also be used for applications where another manufacturer's sensor is used with a Signet 5700 or 8750 instrument.

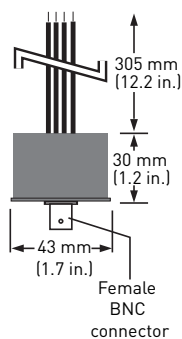



Model 2714-2717 and Model 2720 Ordering Notes:

- 1) Electrodes require purchase of preamplifier for full system installation.
- 2) To replace electrodes, simply untwist from pre-amplifier to replace with new electrode.
- 3) Always purchase a Signet cap and installation fitting for pipe applications.
- 4) Conduit and mounting brackets for submersible installation must always be used (customer supplied).
- 5) Use pipe adapters to install in pipes larger than DN100 (4 in.). Specify socket weld or NPT thread - See page 200 for more information.
- 6) Use 3-2721 remote pre-amplifier when connecting other manufacturers electrodes to Signet instruments.

Application Notes:

- Use the flat glass electrodes when a self-cleaning feature is desired; especially useful in applications with abrasive particles.
- Use bulb protected electrodes for general purpose applications
- ORP electrodes are generally used for chemical reaction monitoring, not process control.
- Ensure that sensor materials are chemically compatible with the process liquid.
- Cleaning and calibration of electrodes is application dependent.

Please refer to Installation, Accessories and Fittings sections for more information.

Ordering Information

Electrode Part Number- Choose either a pH or ORP Electrode	
pH Electrodes	
3-2714	Flat pH surface electrode
3-2714-HF	Flat pH surface electrode, for use in trace HF (hydrofluoric acid) in concentrations < 2%
3-2716	Bulb pH electrode with bulb protection (on plastic body electrodes only)
3-2716-DI	Bulb pH electrode with bulb protection, for process liquids <100 µS/cm conductivity
ORP Electrodes	
3-2715	Flat ORP surface electrode
3-2717	Bulb ORP electrode with bulb protection (on plastic body electrodes only)
Options	
-	For electrodes used in in-line mounting with Signet fittings, use red or blue electrode cap (see sensor caps for in-line mounting)
-WT	Glass electrode with Twist-Lock connector; for use with the 3719 Wet-Tap Assembly Only. Available for Part Numbers 3-2716 and 3-2717 only
3-2714	Example Part Number
3-2716	-WT Example Part Number

Sensor Caps for In-Line Mounting - Choose one (required for initial installation of any pH or ORP electrode)	
P31542	Red Sensor Cap (commonly used for distinguishing pH from ORP sensors)
P31542-3	Blue Sensor Cap (commonly used for distinguishing ORP from pH sensors)
P31542	Example Part Numbers

Preamplifiers - Choose one (required for initial installation of any pH or ORP electrode)	
3-2720	3/4 inch FNPT submersion threads; 4.6m (15 ft.) cable
3-2720-2	ISO 7/1-R3/4 inch FNPT submersion threads; 4.6m (15 ft.) cable
3-2714 and 3-2720	Example Part Numbers

Mfr. Part No.	Code	Mfr. Part No.	Code
3-2714	198 844 300	3-2717	198 844 303
3-2714-HF	198 844 305	3-2717-WT	159 000 811
3-2715	198 844 301	3-2720	198 864 602
3-2716	198 844 302	3-2720-2	198 864 603
3-2716-DI	198 844 306	3-2721	198 864 610
3-2716-WT	159 000 809		

Accessories and Replacement Parts

Mfr. Part No.	Code	Description
Calibration Accessories		
3-2759	159 000 762	pH/ORP System Tester (includes bypass adapter)
3-0700.390	198 864 403	pH Buffer Kit
Mounting		
P31515-0P200	159 000 630	PVC Pipe Adapter, 1.25 in. O.D.
P31515-0C200	159 000 631	CPVC Pipe Adapter, 1.25 in. O.D.
P31515-0V200	159 000 459	PVDF Pipe Adapter, 1.25 in. O.D.
Other		
1220-0021	198 801 186	Replacement O-ring, FPM (for electrodes)
1224-0021	198 820 006	Replacement O-ring, EPDM (for electrodes)
1228-0021	198 820 007	Replacement O-ring, Kalrez® (for electrodes)
5523-0624	159 000 636	Cable, 24 AWG, 6-conductor (specify length)
3-2721	198 864 610	Remote pH/ORP preamplifier
3-2759.393	159 000 765	Adapter cable for use with 2720
P31542	198 801 630	Sensor cap, red
P31542-3	159 000 464	Sensor cap, blue