



3-2754.090 Rev. E 3/06 English

**WARNING!**



**SAFETY INSTRUCTIONS**

1. Depressurize and vent system prior to installation or removal.
2. Confirm chemical compatibility before use.
3. Do not exceed maximum temperature/pressure specifications.
4. Wear safety goggles or faceshield during installation/service.
5. Do not alter product construction.
6. When using chemicals or solvents care should be taken and appropriate eye, face, hand, body, and/or respiratory protection should be used.



## 1. Specifications

**General**

Compatibility: Signet 2750 Electronics  
 Signet 2760 Preamplifiers

Operating Range:  
 • pH: 0 to 14 pH  
 • ORP (Redox):  
 2765, 2767: ±1500 mV  
 2755, 2757: ±2000 mV  
 2775, 2777: ±1500 mV

Wetted Materials (2764 and 2774 series):

- Body: PPS (Ryton®)
- Reference junctions: PTFE (Teflon™)
- Sensing surface: Glass membrane (pH)  
 Platinum (ORP)
- O-rings: FPM
- Solution ground: carbon graphite (2764 series only)

Wetted Materials (2754-2757 Series):

- Body: CPVC
- Reference junctions: UHMW Polyethylene
- Sensing surface: Glass membrane (pH)  
 Platinum (ORP)
- O-rings: FPM

Reference Electrolyte:

- 2754 series electrodes: solidified acrylamide gel, KCl
- 2764 series electrodes: Equitransferant reference buffer acrylamide KNO<sub>3</sub> salt bridge
- 2774 series electrodes: acrylamide gel, KNO<sub>3</sub>/ KCl

Reference Element: Ag/AgCl

Temperature Sensor:

- pH: 3KΩ, PT1000 or 300Ω
- ORP: 10 KΩ, PT1000 or 300Ω

Temperature response time τ :

- 2754 electrodes: 140 s
- 2756 electrodes: 196 s
- 2764, 2774, 2776 series: 20 s

Maximum Temperature/Pressure:

Operating Temperature:

- 2764 series: 0°C to 95°C (32°F to 203°F)
- 2774 series: 0°C to 85°C (32°F to 176°F)
- 2754 series: 0°C to 85°C (32°F to 176°F)

Max. Operating Pressure: 6.89 bar @ 95°C  
 (100 psi @ 203°F)

Storage Temperature: >0°C (32°F)  
 Shipping Weight: 0.25 kg (0.55 lbs.)

Standards & Approvals

- Manufactured under ISO 9001:2000 for Quality

2764 series Differential electrode      2774 series Bulb electrode      2776 series Flat electrode      2754 & 2755 Flat electrode      2756 & 2757 Bulb electrode

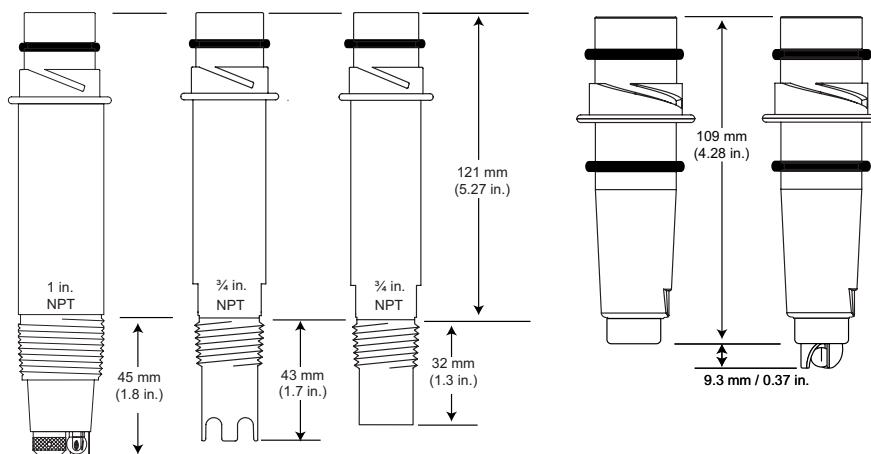

## 2. Electrode care and application

pH/ORP electrodes are similar to batteries; they age with time and usage. The following information will help maximize electrode life.

### 2.1 Conditions to Avoid:

- High temperatures, strong acids or caustics will elevate electrochemical reactions and speed electrode aging.
- Coatings on the glass or junction surfaces (i.e. proteins) cause extended response time and inaccurate measurement.
- Never store the electrode tip in deionized (DI) water. (Use pH 4 buffer solution to keep the glass wet when out of the process.)
- Never expose electrode to temperatures below 0°C (32°F) or allow it to dehydrate. These conditions will damage the electrode.
- Never scrape or sand the glass electrode surface.
- Treat glass electrode surfaces with care to prevent accidental breakage.

### 2.2 Submersible Installation Tips:

- Choose a location that keeps the electrode glass completely submerged at all times.
- Mount electrodes in a location with ample clearance for removal.
- Place the electrode tip in pH 4 buffer during system maintenance or storage to avoid dehydration.
- Mount the electrode near tank outlets, away from reagent addition areas.

### 2.3 In-Line Installation Tips:

- pH and ORP electrodes respond best in moving fluids.
- Standard (2754 series) and Differential (2764 series) electrodes must be mounted at a downward angle (>10° from horizontal). 2774 and 2775 electrodes can be mounted at any angle.

## 3. pH Electrode Calibration

All pH electrodes are designed to provide linear output during their lifespan. The following sections define proper electrode operation.

### 3.1 Offset (STD)

Electrode offsets occur due to:

- Clogged reference junction
- Aged or contaminated reference solution/wire

Check offsets in a pH 7 buffer @ 25°C. The theoretical output is 0 mV. Any deviation from 0 mV is the pH electrode offset.

pH Electrode Offset pH 7 buffer @ 25°C	Theoretical:	7.0 pH (0.0 mV)
	New electrode:	pH 7 ± 0.25 pH (±15 mV)
	Reliable:	pH 7 ± 0.85 pH (± 50 mV)

Electrode offsets greater than 0.85 pH (50 mV) indicate the electrode requires cleaning or replacement. See section 5: Maintenance and cleaning.

Theoretical mV Values @ 25°C	
pH	mV
2	+296 mV
3	+237 mV
4	+177 mV
5	+118 mV
6	+59 mV
7	0 mV
8	-59 mV
9	-118 mV
10	-177 mV
11	-237 mV
12	-296 mV

### 3.2 Slope (SLP)

Electrode slope is the number of mV per pH unit. At 25°C the theoretical slope is 59.16 mV per pH. Temperature has an appreciable affect on electrode slope. Reliable instrumentation includes temperature compensation. The graph below illustrates potential pH error when a temperature compensated instrument is not used.

Recommendations:

- Calibrate temperature before calibrating the standard and slope.
- The mV offset will track across the entire pH range. The slope is usually not affected by offset changes. (i.e. pH 7= +10 mV, pH 4= +187 mV); slope = 59 mV
- Coatings on the glass may affect sensor slopes. See section 5 maintenance and cleaning.
- A constant output near 0 mV in all buffer solutions indicates a shorted electrode that must be replaced.

°C	pH Error										
	2	3	4	5	6	7	8	9	10	11	12
15	0.15	0.12	0.09	0.06	0.03	0	0.03	0.06	0.09	0.12	0.15
25	0	0	0	0	0	0	0	0	0	0	0
35	0.15	0.12	0.09	0.06	0.03	0	0.03	0.06	0.09	0.12	0.15
45	0.3	0.24	0.18	0.12	0.06	0	0.06	0.12	0.18	0.24	0.3
55	0.45	0.36	0.27	0.18	0.09	0	0.09	0.18	0.27	0.36	0.45

### 3.3 Response Time/Stability

Response time and stability are affected by the condition of the pH glass measuring surface (ORP electrode - Platinum surface), the reference junction, and and the reference solution. Restoration to acceptable levels can often be accomplished by cleaning the measuring surface and reference junction.

Electrode mV values should remain stable ±3 mV. Conditions that may cause fluctuations are:

- Electrode coating
- Ground fault: If proper operation is observed in the beaker, but readings are unstable in the application, a ground fault may exist.
  - Using instrumentation with isolated inputs and outputs may restore stable operation.
  - Solution grounding may also restore stable operation.

#### 4. ORP Electrode Calibration

ORP electrodes are designed to ensure linearity during their lifespan. The following sections define proper electrode operation.

##### 4.1 Offset (STD)

- Electrode offsets are usually caused by clogged reference junctions or by aged or contaminated reference solution/wire.
- Offsets should be checked in pH 7 buffer saturated with quinhydrone @ 25°C. The theoretical output is +86 mV. Any deviation from +86 mV is the ORP electrode offset (i.e. +90 mV).
- Quinhydrone is the oxidizer measured by the ORP electrode and is required for calibration. To measure ORP electrode offset, saturate 50 mL of pH 4 and pH 7 buffers with 1/8 g quinhydrone:

	4 pH w/Quinhydrone			7 pH w/Quinhydrone		
<b>Temp:</b>	20°C	25°C	30°C	20°C	25°C	30°C
<b>ORP:</b>	268 mV	263 mV	258 mV	92 mV	86 mV	79 mV

A new ORP electrode measures these values ±15 mV. The electrode continues to be functional until the offset from these values exceeds 50 mV. Electrodes with offset greater than 50 mV should be cleaned and replaced if necessary.

##### 4.2 Slope (SLP)

ORP slope errors are generally caused by contamination of the platinum electrode surface. Cleaning the electrode surface will usually restore proper values, response time, and stability. See section 5: Maintenance and Cleaning.

Many systems require both pH and ORP calibration. To conserve calibration reference solutions, use pH 7 and 4 buffers for pH calibration first. ORP calibration can be performed with the same buffers by adding quinhydrone.

#### 5. Maintenance and Cleaning

##### 5.1 Maintenance

Variables can affect long term pH or ORP electrode life. For this reason, a maintenance log is recommended for trend analysis. When storing boxed sensors, lay the sensor flat to maximize hydration of the glass surface. Keep the glass surface wet at all times. Soak the sensor tip in pH 4.0 buffer during system maintenance intervals. In-line applications should be plumbed with a depression (trap) so liquid is maintained around the sensor tip. If the sensor dehydrates, soak the sensor tip in pH 4 buffer for 24 to 48 hours, then visually inspect the electrode for surface cracks, swelling, or discoloration. Severely dehydrated electrodes cannot be restored to normal operation.

##### 5.2 Cleaning

Cleaning techniques vary depending on the type of coating present on the glass electrode surface or reference junction.

- Soft coatings can be removed by vigorous stirring, or with directed spray of an applicable detergent or solvent onto the glass surface. Chlorine bleach or mild detergent can be used to remove soft coatings. Always rinse electrode tip in clean water after cleaning.
- Hard coatings can be chemically removed. Use the least harsh chemical which will remove the contaminant within two (2) minutes without attacking the materials of construction. e.g. calcium carbonate may be removed with a 5% HCL (muriatic acid) solution.
- Oily or organic coatings can be removed with detergents or an appropriate solvent that does not attack the materials of construction e.g. isopropyl alcohol may be used but acetone must be avoided to prevent damage to the CPVC sensor body.
- ORP electrode surface (platinum rod) can be gently sanded with 600 grit wet and dry silicone or carbide sandpaper, jewelers rouge, crocus cloth, or very fine steel wool.

##### 5.3 Differential Electrodes

Differential electrodes have a replaceable salt bridge and the electrolyte chamber can be refilled.

The electrolyte chamber should be full. If any fluid is audible when shaken, the chamber should be refilled.

Refill the electrolyte chamber when the electrode offset exceeds 50 mV.

The salt bridge should be replaced when performance becomes sluggish, or if the output is erratic or inaccurate.

Replacing the salt bridge

Parts Required: Salt Bridge (order number 3864-0001) and Differential Reference Solution (order number 3864-0002)

Tools Required: small pliers

1. Remove sensor from mounting.
2. Hold upside down and unscrew salt bridge using a pair of small pliers. Be careful not to damage the glass bulb!
3. Drain the depleted reference solution and dispose of properly.
4. Fill reference chamber with fresh reference solution (approx. 30 ml).
5. Replace salt bridge and screw finger tight. Solution will drip out while screwing in salt bridge. Use pliers to turn approximately 1/4 turn past finger-tight.
6. Perform calibration (standard and slope) before returning the system to service.



##### NOTE:

The refillable electrolyte chamber in 2764 series Differential electrodes may leak during storage and shipping. Check the fluid and refill before installation if necessary.



##### WARNING!

Wear appropriate eye, face, hand, body, and respiratory protection when using chemicals or solvents.

## Ordering Information

Mfr. Part No.	Code	Description
DryLoc pH Electrodes		
3-2754	159 000 747	Electrode, pH, DryLoc, flat, PT1000
3-2754-1	159 001 380	Electrode, pH, DryLoc, flat, 3K $\Omega$
3-2754-HF	159 000 748	Electrode, pH, DryLoc, flat, PT1000, HF-resist (<2%)
3-2754-HF-1	159 001 381	Electrode, pH, DryLoc, flat, 3K $\Omega$ , HF-resist (<2%)
3-2756	159 000 750	Electrode, pH, DryLoc, bulb, PT1000
3-2756-1	159 001 397	Electrode, pH, DryLoc, bulb, 3K $\Omega$
3-2756-DI	159 000 751	Electrode, pH, DryLoc, bulb, PT1000, DI (<100 $\mu$ S)
3-2756-DI-1	159 001 382	Electrode, pH, DryLoc, bulb, 3K $\Omega$ , DI (<100 $\mu$ S)
3-2764-1	159 000 943	Electrode, pH, DryLoc, flat, 3K $\Omega$ , differential, 1 in. NPT process connection
3-2764-2	159 000 944	Electrode, pH, DryLoc, flat, PT1000, differential, 1 in. NPT process connection
3-2764-3	159 000 945	Electrode, pH, DryLoc, flat, 300 $\Omega$ , differential, 1 in. NPT process connection
3-2766-1	159 000 949	Electrode, pH, DryLoc, bulb, 3K $\Omega$ , differential, 1 in. NPT process connection
3-2766-2	159 000 950	Electrode, pH, DryLoc, bulb, PT1000, differential, 1 in. NPT process connection
3-2766-3	159 000 951	Electrode, pH, DryLoc, bulb, 300 $\Omega$ , differential, 1 in. NPT process connection
3-2774	159 000 955	Electrode, pH, DryLoc, flat, 3K $\Omega$ , 3/4 in. NPT process connection
3-2774-1	159 000 956	Electrode, pH, DryLoc, flat, PT1000, 3/4 in. NPT process connection
3-2776	159 000 959	Electrode, pH, DryLoc, bulb, 3K $\Omega$ , 3/4 in. NPT process connection
3-2776-1	159 000 960	Electrode, pH, DryLoc, flat, PT1000, 3/4 in. NPT process connection
DryLoc ORP (Redox) Electrodes		
3-2755	159 000 749	Electrode, ORP, DryLoc, flat, 10K $\Omega$ ID
3-2757	159 000 752	Electrode, ORP, DryLoc, bulb, 10K $\Omega$ ID
3-2765-1	159 000 946	Electrode, ORP, DryLoc, flat, 10K $\Omega$ ID, differential, 1 in. NPT process connection
3-2765-2	159 000 947	Electrode, ORP, DryLoc, flat, PT1000, differential, 1 in. NPT process connection
3-2765-3	159 000 948	Electrode, ORP, DryLoc, flat, 300 $\Omega$ , differential, 1 in. NPT process connection
3-2767-1	159 000 952	Electrode, ORP, DryLoc, bulb, 10K $\Omega$ ID, differential, 1 in. NPT process connection
3-2767-2	159 000 953	Electrode, ORP, DryLoc, bulb, PT1000, differential, 1 in. NPT process connection
3-2767-3	159 000 954	Electrode, ORP, DryLoc, bulb, 300 $\Omega$ , differential, 1 in. NPT process connection
3-2775	159 000 957	Electrode, ORP, DryLoc, flat, 10K $\Omega$ ID, 3/4 in. NPT process connection
3-2775-1	159 000 958	Electrode, ORP, DryLoc, flat, no tc, 3/4 in. NPT process connection
3-2777	159 000 961	Electrode, ORP, DryLoc, bulb, 10K $\Omega$ ID, 3/4 in. NPT process connection
3-2777-1	159 000 962	Electrode, ORP, DryLoc, bulb, no tc, 3/4 in. NPT process connection

## Accessories and Replacement Parts

Mfr. Part No.	Code	Description
3-2750-1	159 000 744	In-line Sensor Electronics w/Junction Box
3-2750-2	159 000 745	In-line Sensor Electronics w/Junction Box and Easy-Cal
3-2750-3	159 000 746	Submersible Sensor Electronics with 15 ft. cable, 3/4 in. NPT threads
3-2750-4	159 000 842	Submersible Sensor Electronics with 15 ft. cable, ISO 7-1/R3/4 threads
3-2760-1	159 000 939	Submersible Preamplifier with 3/4 in. NPT threads and 4.6 m (15 ft.) cable
3-2760-2	159 000 940	Submersible Preamplifier with 3/4 in. ISO threads and 4.6 m (15 ft.) cable
3-2760-3	159 000 941	Submersible Connector with 4.6 m (15 ft.) cable and 3/4 in. NPT threads
3-2760-4	159 000 942	Submersible Connector with 4.6 m (15 ft.) cable and ISO 7/1R 3/4 in. threads
3-2760-11	159 001 367	In-line Preamplifier with 3/4 in. NPT threads and 4.6 m (15 ft.) cable
3-2760-21	159 001 368	In-line Preamplifier with 3/4 in. ISO threads and 4.6 m (15 ft.) cable
3-2760-31	159 001 369	In-line Connector with 4.6 m (15 ft.) cable and 3/4 in. NPT threads
3-2760-41	159 001 370	In-line Connector with 4.6 m (15 ft.) cable and ISO 7/1R 3/4 threads
3-0700.390	198 864 403	pH Buffer Kit (1 each 4, 7, 10 pH buffer in powder form, makes 50 mL)
3864-0001	159 001 007	Replacement Salt Bridge for Differential electrodes
3864-0002	159 001 008	Reference solution refill for Differential electrodes, 500 mL (approx. 12 refills)
5523-0624	159 000 636	Cable, 6 conductor, 24 AWG, shielded
3-2759	159 000 762	pH/ORP System Tester (adapter cable sold separately)
3-2759.391	159 000 764	2759 DryLoc Adapter Cable (for use with 2750 and 2760)



George Fischer Signet, Inc., 3401 Aerojet Avenue, El Monte, CA 91731-2882 U.S.A. • Tel. (626) 571-2770 • Fax (626) 573-2057  
For Worldwide Sales and Service, visit our website: [www.gfsignet.com](http://www.gfsignet.com) • Or call (in the U.S.): (800) 854-4090

